

OVERLOCK STITCH

700L 700LD 700KST 700KS 700KT

747 L - 514 M - 2 - 2 4 / VT

线数
Thread numbers

737 : 3T
747 : 4T
757 : 5T
767 : 6T

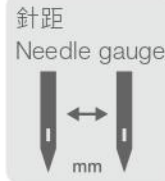

配件
Device

机种别 Model	缝合方式 Sewing types	车缝布料/ 上勾针缝容量 Sewing Fabric / Upper Looper capacity	送具型式 Feed dog type
L 超高速包缝/ 安全缝 Ultra High Speed Overlock/ Safety Stitch	503	F 轻薄布料 Fine weight fabric	1 1排 (標準) 1 row (standard)
LD 直驅超高速包缝/ 安全缝 Direct-Drive Ultra High Speed Overlock/ Safety Stitch	504	L 薄布料 Light weight fabric	2 2排 (標準) 2 row (standard)
KST 筒型上送包缝 Cylinder-bed Top-feed High Speed Overlock	505	M 中厚布料 Medium weight fabric	3 3排 (標準) 3 row (standard)
KS 筒形包缝 Cylinder-bed High Speed Overlock	512	H 厚布料 Heavy weight fabric	4 4排 (標準) 4 row (standard)
KT 上送包缝/ 安全缝 Top-feed High Speed Overlock/ Safety Stitch	514	X 特厚布料 Extra heavy weight fabric	5 5排 (標準) 5 row (standard)
	516		6 1排 (特殊) 1 row (special)
	644 (514+401)		7 2排 (特殊) 2 row (special)
			8 3排 (特殊) 3 row (special)
			9 4排 (特殊) 4 row (special)
			0 5排 (特殊) 5 row (special)

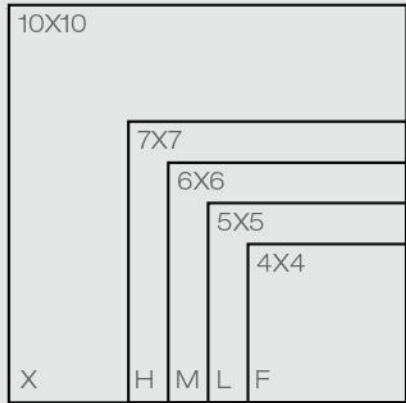

卓越性能 来自不断的淬炼

Excellent performance comes from constant refinement

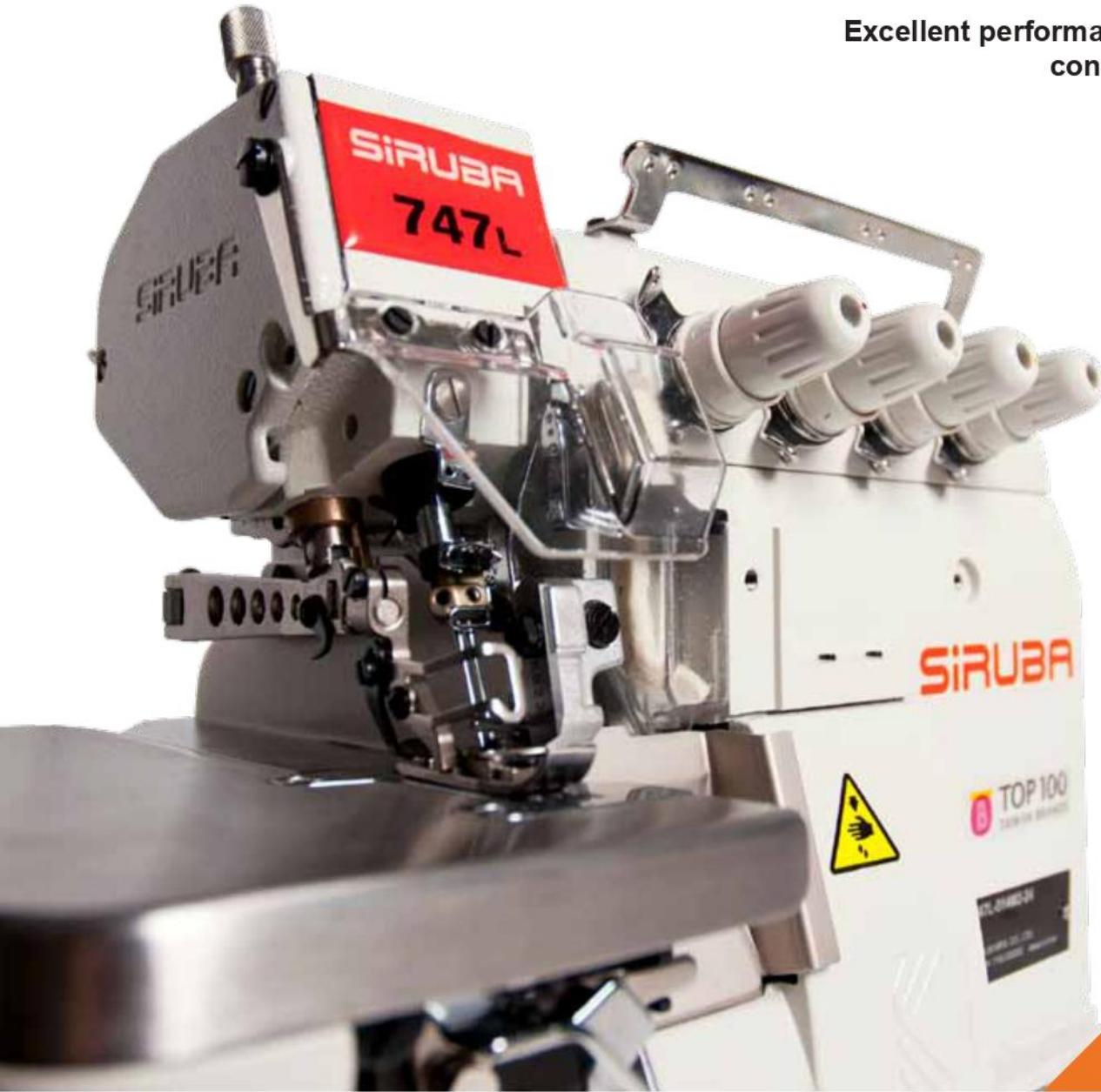

700L SERIES

700L 超高速包缝 / 安全缝纫机
Ultra High Speed Overlock / Safety
Stitch Machine

700LD 直驱超高速包缝 / 安全缝纫机
Direct-drive Ultra High
Speed Overlock / Safety
Stitch Machine



700L series

在 Siruba 包缝机技术的既有基础上，大幅度提升性能
Based on Siruba overlock technology, we greatly enhance the performance.

在控线与送布的根本性能的追求，实现了完美的缝纫质量

过线系统全面优化，在每一个细节都考虑了线的张力状态，实现了极佳的控线能力。送具、压具与切布刀的综合调校，使得送布性能达到优化。在面料的厚薄适用性，700L在规格上有更全面的对应，实现了令人满意的车缝质量。

在机械精度的追求，达到高速运转下的稳定性

提升零件的制造工艺，在精度、表面处理、内孔精加工和零件的轻量化设计，每一个细节都有严谨的配合，实现了高速、稳定、低噪音与低振动的机械性能。

车缝应用的范围更广

针对车缝面料的厚度，在规格上(包括规格组、上勾针行程、机构时位...等)有更全面的对应，在超薄或超厚的车缝情形，都有令人满意的车缝质量

In pursuit of the core performance of thread controlling and fabric feeding, it realizes perfect sewing quality.

Threading system is fully optimized. As we fine-tuned every detail about the thread tension, it realizes a very good thread controlling. The feed dog, presser foot, and fabric trimmer are well coherent to make the fabric feeding optimized. Regarding the applicability range of fabric weight, 700L has a more comprehensive correspondence by specification, and realizes the satisfactory seam quality.

In pursuit of mechanical precision, it realizes the stability under high speed operation.

Improving the spare parts manufacturing process, the spare parts manufacturing process is improved. As the precision, surface treatment, micro-finish honing and parts light weight design are strictly coordinated in details, it realizes the high speed, stable, low noise and vibration mechanical performance.

The bigger range of sewing application

Regarding sewing material thickness, we have a full specification (including gauge set, upper looper stroke, mechanical timing...etc) to satisfy customer requirement. We provide the nice seam quality in sewing fine or extra heavy material.

规格

SPECIFICATIONS

700L	布料厚度 Fabric Weight			1	2	+ ↓ +	4	0.7-2	3.6	6	! DCX27	S.P.M. (Max)
	L	M	H									
一般包缝 General Seaming	737L-503M-3-04			1	2	-	4	0.7-2	3.6	6	#11	7500
	737L-504F-2-04			1	3	-	4	0.7-2	3.6	5	#11	7500
	737L-504M-3-0□			1	3	-	4,5	0.7-2	3.6	6	#11	7500
	747L-512M-3-25			2	4	2	5	0.7-2	3.6	5.5	#11	7500
	747L-512M-3-34			2	4	3	4	0.7-2	3.6	5.5	#11	7500
	747L-514M-3-2□			2	4	2	3,4,5	0.7-2	3.6	5.5	#11	7500
	747L-514H-3-28			2	4	2	8	0.7-2	3.6	4	#11	6500
	757L-516L-2-24			2	5	2	4	0.7-2	3.6	5.5	#14	7500
	757L-516L-2-35			2	5	3	5	0.7-2	3.6	5.5	#14	7500
	757L-516M-3-35			2	5	3	5	0.7-2	3.6	5.5	#14	7500
	757L-516M-3-55			2	5	5	5	0.7-2	3.6	5.5	#14	7500
	767L-644M-3-324			3	6	3+2	4	0.7-2	3.6	5	#11	7000
767L-644M-3-524			3	6	5+2	4	0.7-2	3.6	5	#11	7000	

700L		布料厚度 Fabric Weight			1	4	2	3	0.7-2	3.6	5	#11	7500
		L	M	H									
超薄布防起皺 Fine Fabric with Anti Puckering	747L-514F-3-23				2	4	2	3	0.7-2	3.6	5	#11	7500
	747L-514F-3-24				2	4	2	4	0.7-2	3.6	5	#11	7500
	757L-516F-2-34				2	5	3	4	0.7-2	3.6	5	#11	7500
細包縫 Fine Edging	737L-504F-2-02/GAL				1	3	-	2	0.7-2	3.6	5	#9	7500
	737L-504F-2-15				1	3	-	1.5	0.7-2	3.6	5	#9	7500
	737L-504M-2-15				1	3	-	1.5	0.7-2	3.6	6	#9	7500
肩帶包縫 Tape Inserting	747L-514M-3-24/TG				2	4	2	4	0.7-2	3.6	5.5	#11	7500
	747L-514M-3-25/TG				2	4	2	5	0.7-2	3.6	5.5	#11	7500
拷下擺 Blind Hemming	737L-505F-2-04				1	3	-	4	0.7-2	3.6	5	#9	7500
松緊帶車縫 Elastic Attaching	737L-504M-3-04/LFC-3				1	3	-	4	0.7-2	3.6	6	#11	6500
	747L-514M-3-2□/LFC-3				2	4	2	4,5	0.7-2	3.6	5.5	#11	6500
	747L-514M-3-2□/SMK				2	4	2	4,5	0.7-2	3.6	5.5	#11	7500
	737L-504M-3-04/TR				1	3	-	4	0.7-2	3.6	6	#11	7500
摺景車縫 Gathering	747L-514M-8-24/GA				2	4	2	4	0.7-2	3.6	5.5	#11	7000
	757L-516M-8-35/GA				2	5	3	5	0.7-2	3.6	5.5	#14	7000
	757L-516M-8-55/GA				2	5	5	5	0.7-2	3.6	5.5	#14	7000
手動線頭包縫 Manual Back Latching Seaming	737L-504M-7-04/BK(BK-1)				1	3	-	4	0.7-2	3.6	6	#11	7500
	747L-514M-7-2□/BK(BK-1)				2	4	2	3,4,5	0.7-2	3.6	5.5	#11	7500
	747L-514H-7-2□/BK(BK-1)				2	4	2	4,5	0.7-2	3.6	7	#16	7500
全自動手動線頭包縫 Fully Auto Back Latching Seaming	737L-504M-5-04/BKF				1	4	2	4	0.7-2	3.6	6	#11	7500
	747L-514M-5-23/BKF				2	4	2	4	0.7-2	3.6	5.5	#11	7500
厚毛衣料包縫 Over Seaming On Bulky Knitwear	747L-514H-4-24				2	4	2	4	0.7-2	3.6	7	#16	6500
	747L-514H-4-25				2	4	2	5	0.7-2	3.6	7	#16	6500
牛仔安全縫 Jeans Safety Stitch	757L-516H-3-5□				2	5	5	5,6	0.7-2	3.6	7	#16	6000
	757L-516X-3-5□				2	5	5	5,6	0.7-2	3.6	7	#16	6000
厚毛衣料肩帶包縫 Tape Inserting On Bulky Knitwear	747L-514H-4-24/TG				2	4	2	4	0.7-2	3.6	7	#16	6500
	747L-514H-4-25/TG				2	4	2	5	0.7-2	3.6	7	#16	6500
口袋包縫 Pocket Binding	757L-516M-3-35/PS				2	5	3	5	0.7-2	3.6	5	#14	7000
	757L-516M-3-55/PS				2	5	5	5	0.7-2	3.6	5	#14	7000
	757L-401M-8-□/TA				2	4	3,5	-	0.7-2	3.6	5	#14	7000
	767L-644M-3-324/PS				2	6	3+2	4	0.7-2	3.6	5	#14	7000
	767L-644M-3-524/PS				2	6	5+2	4	0.7-2	3.6	5	#14	7000
管狀布條車縫 Spaghetti Sewing	737L-WR/LFC-3				1	3	-	-	0.7-2	3.6	-	#11	6000
拉鏈包縫 Zip Seaming	737L-504M-3-05/PZ				1	3	-	5	0.7-2	3.6	6	#14	7500
毛巾布邊車縫 Towel Edging	757L-401M-6/TW				1	2	-	-	0.7-2	3.6	5	#14	7500

詳細配件資訊請參考Siruba綜合目錄

Please refer to Siruba General Catalogue for the device's information.



700LD/DKLT1

承续 700QD 系列的丰富实战经验，Siruba 电控技术再提升

Based on the rich experience of 700QD Series, Siruba upgrades the control technology.

采用高速伺服马达

- 以充沛的动力，实现7500 RPM的运转速度
- 制造精度高，噪音小，发热低

控制器模块化设计，以多种组合，全方位满足各种需求

- 经济型：节能省电，并可驱动EC切布条装置
- 多功能型：标配电眼，侦测布料边缘，以进行自动模式车缝，并可切换半自动或手动模式
- 多功能型分为气动型与电动型，依客户的厂房设备，选择适合的规格

采用新型电眼，更灵敏，更精准，侦测无死角

- 体积小，安装于车布板下方，单一方向侦测布边
- 不需调整电眼位置，适用于各种车缝作业情形
- 克服因棉絮阻挡而造成感测失灵的问题

The high speed servo motor

- By the plenty power, it realizes the operation speed of 7500 RPM.
- High precision makes low noise level and low heat.

The controller modularized design, with a variety of combinations, comprehensively meets the various demands.

- Economic type: Energy saving, and also drives EC device, electrical tape cutter
- Multi-function type: the sensor checks fabric edge for automatic sewing mode. Also semi-auto or manual mode can be switched on demand.
- Multi-function type includes pneumatic and electrical type. Customers may choose the suitable specification according to the factory facility.

The new sensor is more sensitive, more accurate, no blind spot.

- It is very small, installed under the sewing bed, detecting the fabric by single direction.
- No need to adjust the position, apply to a variety of sewing operations.
- Overcoming the problem of sensory failure due to dust blocking.

700LD

产品组合：配件与直驱电控组

Product Package: Devices and Direct-Drive Control Sets

直驱电控组 Direct-drive Control Set	配件 Device	功能 Function	配件表 Accessory List												
			电眼 Sensor	安全 开关 Safety Switch	操作 面板 Control Panel	手动 开关 Manual Cut Switch	松线 Thread Release	切布条 Tape Cutter	吸风切线 Suction Trimmer		LED 照明 LED Light	立式 踏板 Standing Operation Padel	抬压脚 Auto Foot Lifter	吸风组 Suction Set	
									侧切 Side Cutter	平切 Flat Cutter					
DKLT1-0 經濟型 (输出x 2) Economic Type (Output x 2)	DKLH1-0 經濟型 (输出X 3) Economic Type (Output x 3)	一般车缝 General Sewing									●				
		VT 吸风切线 Suction Thread Trimmer							●		●		#5	#4 #5	
		CT 吸风切线 Suction Thread Trimmer								●	●		#5	#4 #5	
		AC 氣動切布條 Pneumatic Type Tape Cutter				●			●		●				
		EC 电动切布条 Electric Type Tape Cutter				●			●		●				
DKLT1-1 or DKLH1-1 多功能 气动型 (输出x 5) Multi-function Pneumatic Type (Output x 5)	ECA 气动切布条 Air Type Tape Cutter	●	●	●	●			●		●		#2	●	●	
	VTE 吸风切线 Suction Thread Trimmer	●	●	●		#1		●		●		#2	●	●	
	VTA 吸风切线 Suction Thread Trimmer	●	●	●		#1		●		●		#2	●	●	
	CTE 吸风切线 Suction Thread Trimmer	●	●	●		#1			●	●		#2	●	●	
	UC 上下層防捲邊 Top and Bottom Anti-Curly Edge		●	●					●		●	#2	●	●	
	BKT 簡易型自动包线头 Simplified Auto Back Latch	●	●	●	●	●	●				●	#2	●	●	
DKLT1-2 or DKLH1-2 多功能 电动型 (输出x 5) Multi-function Electric Type (Output x 5)	ECB 电动切布条 Electric Type Tape Cutter	●	●	●	●			● Solenoid Type		●		#2	● Solenoid Type	#3	
	VTE 吸风切线 Suction Thread Trimmer	●	●	●		#1		●		●		#2	● Solenoid Type	●	
	CTE 吸风切线 Suction Thread Trimmer	●	●	●		#1		●		●		#2	● Solenoid Type	●	

备注:
●标准配备 / # 選配
#1: BK321-4
#2: EC467-A
#3: 1. ECB-A 氣電混合型(可控制吸風時間)
2. TUD-2 純電型(無電刷吸風馬達+前後吸風組)
#4: 1. TUA-31 需有空壓設備
2. TUD-2 無電刷馬達驅動
#5: TUA-32K 需有空壓設備

Remark:
● Standard accessory / # Optional accessory
#1: BK321-4
#2: EC467-A
#3: 1. ECB-A Air-mixed type (suction timing control)
2. TUD-2 Pure Electric type (Suction motor + front & rear suction set)
#4: 1. TUA-31 Air compressor is required.
2. TUD-2 Driven by Brushless motor
#5: TUA-32K Air compressor is required.

TUA-3X

三合一吸风集尘组
3-IN-1 SUCTION DEVICE

代号 Code	功能组件 Functional Section			搭配 配件 Collocated Device	备注 Remark
	三吸组 3-In-1 Suction Set	气动抬押脚 Pneumatic Presser Foot Lifter	机械阀 Mechanical Type Air Switch		
TUA-31	V	V	单联 Single way	VT CT	700L 700LD / DKLT1-0
TUA-32K			双联 Double ways		



备注: 吸风组为 700LD 电眼型之标准配备
Remark: The suction set is standard accessory of 700LD sensor type models.

ECA
ECB

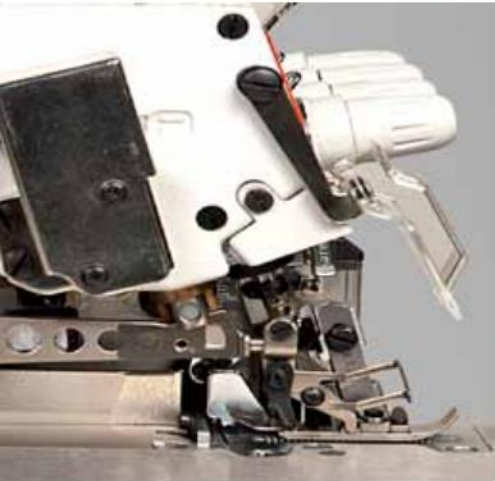

UC

CTE
VTA
VTE

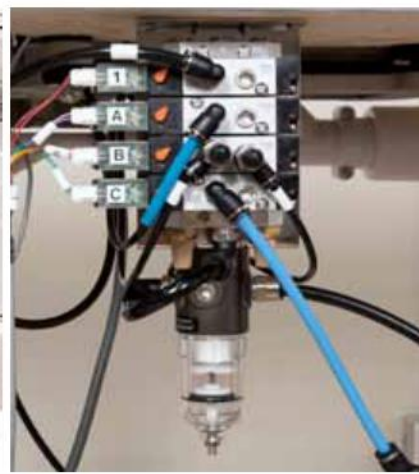

BKT



ECA 气动式切刀
PNEUMATIC TYPE TAPE/THREAD CUTTER

采用新一代的电眼，性能再升级。ECA为气动式，ECB为电动式，搭配吸风线槽，操作更顺畅。

- 1.手动、半自动及全自动操作模式,附转换按键,且可透过操作面板调整。
- 2.防误切保护装置:切刀旁安装一电眼,如有被遮挡的状况下,切刀不会动作,能有效地防止切刀误切到布料。
- 3.手动切线补偿按键,如因操作问题没有切断线,可透由此按键进行手动切线。
- 4.手动模式下,可后踩踏板切线。
- 5.针对网纱、强反光丝光棉等特殊面料,采用专业的电程式控制,均能轻松车缝及完成切线,不会造成切刀误切。

Brand new sensor upgrades the performance. ECA is pneumatic type, and ECB is electric type, compatible with air suction slot, which makes the operation more smoothly.

1. Manual, semi-auto and fully-auto operation mode, attached the switch keys, and could be adjusted by the panel.
2. Mistake-proof protection device: One sensor equipped near the trimmer. If the sensor is blocked, the trimmer is deactivated effectively for avoiding from cutting the fabric.
3. Manual trimming compensation stitch key: If the thread is not cut due to the operation, it can be done by the key.
4. Under the manual mode, it could be fully backward pedaled to cut the thread.
5. For those special fabrics such as mesh fabric, mercerized cotton etc, the stitches are easily accomplished as well as the trimming by the professional computer controlled without mistake-trimming.

ECB 电动式切刀
SOLENOID TYPE TAPE/ THREAD CUTTER

ECB-A ECB+ 气动吸风组
ECB+PNEUMATIC SUCTION SET



CTE 水平式
FLAT TYPE

吸风切线 (附电眼节能装置)
SUCTION CHAIN-CUTTER (WITH SENSOR-CONTROLLED ENERGY-SAVING DEVICE)

以电眼侦测布边,控制吸风功能在切线时运作,减少空压设备的能源消耗,并避免缝线浪费。

- 1.垂直式吸风切线适合内裤厂等轻薄及不规则的针织面料车缝,提升效率。
- 2.切刀之吸风口的设计使得切线更加快速。
- 3.针对网纱、强反光丝光棉等特殊面料,采用专业的电程式控制,均能轻松车缝及完成切线,不会造成切刀误切。
- 4.«切线後自动停车功能»以及«无面料即不车缝功能»可减少缝线的浪费。
- 5.VTA以气缸推动切刀,减少刀刃磨损,大幅延长使用寿命

Electric eye (sensor) checks the fabric edge. It saves the energy consuming of air compressor system and also saves thread consuming.

1. Vertical suction trimming is suitable for sewing the light fabric like under-wear or irregular knitwear, to improve the efficiency.
2. The design of the suction inlet of the trimmer makes the trimming faster.
3. For those special fabrics such as mesh fabric, mercerized cotton etc, the stitches are easily accomplished as well as the trimming by the professional computer controlled without mistake-trimming.
4. Functions with auto stop sewing after trimming and with no fabric can save the stitches.
5. VTA trimmer is controlled by air cylinder, which reduces the blade stroke times and extends the durability.

VTA **VTE** 垂直式
SIDE TYPE



BKT 简易式自动包线头
SIMPLY AUTO BACK LATCH

为ECA延伸功能,车缝效率极高,针板有特殊风道设计,线头在切线後,瞬间吸回,线头长度约3cm

It is an ECA extending function. The sewing efficiency is very high. Special needle plate suction channel is for thread-end down turning. It pulls back the chain while a wink. The back latch length is about 3cm.



UC 上下层防卷边
TOP AND BOTTOM ANTI-CURLY MATERIAL

针对易卷曲布料所开发的气动装置,在布料进入压脚之前,将布料吹平,可适用上卷,下卷等各种卷曲的情形,大幅增加车缝效率。

The pneumatic device solves the problem of curly edge material. The fabric edge is flattened by air before entering the presser foot. Applicable to up-roll, down-roll, and all kinds of curly edge situations, which highly improves the sewing efficiency.

SD 圆领衫颈後贴条
T-Shirt Neck-back Tape Attaching



以气动方式控制喇叭的水平位置(布条上料与切断),标准喇叭之规格:入布宽度36mm,出布宽度18mm

Control the folder's horizontal positions (tape feeding and cutting). Standard folder's specification: Tape width 36mm, finish width 18mm.



700KS/KST SERIES FEATURES

700KS

高速筒型包缝机
High Speed Cylinder Bed Overlock Machine

700KST

高速筒型上送包缝机
High Speed Cylinder Bed Top Feed Overlock Machine



延续700K系列之特点，发展筒型机构延伸成为700KS系列。再增加新型独立驱动的上送具机构，延伸成为700KST系列。

Succeeding 700K Series' features, we develop cylinder bed mechanism to extend to 700KS Series. Moreover, with brand new independent-drive top feed mechanism, it extends to 700KST Series.

- 筒嘴周长: 148mm
- 缝距调整: 按钮式
- 差动比调整: 手杆式
- 润滑系统: 全自动

- Cylinder Bed Circumference: 148mm
- Stitch Length Adjustment: Push-button
- Differential Feed Ratio Adjustment: Lever type
- Lubrication: Fully-automatic

700KS

											选购配件 OPTIONAL DEVICE
下摆盲缝 Blindstitch Hemming	737KS-505F-2-04	1	3	-	4	0.7~2.0	3.8	5	#9	6500	VT LFD6K-□ RLK-□
	737KS-505F-2-04/ESK										
一般包缝 General Sewing	737KS-504M-3-0□	1	3	-	3,4,5	0.7~2.0	3.8	5	#11	6500	
	737KS-504H-3-0□	1	3	-	3,4,5	0.7~2.0	3.8	6	#11	6300	
	747KS-514M-3-2□	2	4	2	3,4,5	0.7~2.0	3.8	5	#11	6500	
	747KS-514H-3-2□	2	4	2	3,4,5	0.7~2.0	3.8	6	#11	6300	

700KST

											选购配件 OPTIONAL DEVICE
下摆盲缝 Blindstitch Hemming	737KST-505F-2-04	1	3	-	4	0.7~2.0	0.5~6	3.8	5	#9	6300
一般包缝 General Sewing	737KST-504M-3-0□	1	3	-	3,4,5	0.7~2.0	0.5~6	3.8	5	#11	6300
	737KST-504H-3-0□	1	3	-	3,4,5	0.7~2.0	0.5~8	3.8	6	#11	6000
	747KST-514M-3-2□	2	4	2	3,4,5	0.7~2.0	0.5~6	3.8	5	#11	6300
	747KST-514H-3-2□	2	4	2	3,4,5	0.7~2.0	0.5~8	3.8	6	#11	6000



ESK 电子盲缝拷下摆装置
Electric hemming guide

ESS 电子盲缝拷下摆装置(附自动升起功能)
Electric hemming guide (with auto-rising function)

盲缝拷下摆之車縫工序中, ESK可防止在過骨時發生脫線問題, 全套配備直驅馬達, VT吸風切線, TUA集塵組, 自動抬壓腳

In blindstitch hemming operation, ESK prevents stitch skipping or ply-shifting at the cross seam sections. The full set includes direct-drive servo motor, VT side suction trimmer, TUA suction set, auto foot lifter.

上圓領系列

CIRCULAR COLLAR ATTACHING SERIES

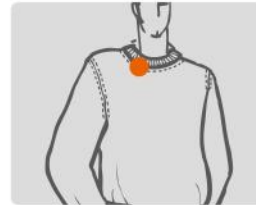

KCL



RSK



ACS

KCL 气动导布与撑开轮组
RSK Pneumatic guide and tubular extending Roller set

气动式导布带组,左右两侧紧靠圆领布带,配合滚轮撑开组,使得圆领布带能够稳定的前进,车工只需控制大身裁片,提升效率,降低车缝工序的难度

Pneumatic tape guide set holds the neckband's right and left side. With tubular extending roller set, the neckband tape can move forward stably so that operators can focus on fabric control, which improves the efficiency and reduces the difficulty of sewing operation.



ACS 气动导布与撑开轮组(附自动定位功能)
Pneumatic guide and tubular extending Roller set (with auto-positioning function)

在气动导布与滚轮撑开的基础上,加上自动顺布条,接缝骨自动定位,减少90%的上料时间,

Based on Pneumatic tape guide and tubular extending roller set, with advanced function as Automatic tape alignment, automatic Joint-seam positioning, which reduce 90% material loading time.





LFD6K 多功能自动松紧带包缝(700KS 適用) Multi-function computerized automatic elastic attaching (700KS Applicable)

对于松紧带之包缝，可利用计算机控制，进行自动切带与自动送带。可设定多段之松紧度与车缝长度，适用于泳衣，紧身衣，内裤等小口径松紧带上带车缝，新增以下特点

送具下沉功能：壓腳抬起時，送具自動下沉，確保送帶零阻礙

直驅伺服馬達：電控功能高度整合，動作配合更精確

觸控面板：圖形介面，設定更容易，新增測試模式，更快上手

For attaching elastic tape on small openings of swimsuit, leotards or brief, etc. By computer control, with auto cutting and auto tape feeding, elastic tape sewing can be done by multi-section tension and length., with the below features:

Feed dog dropping function : when presser foot lifts, the feed dog drops to ensure tape feeding without obstacle.

Direct drive servo motor : Electrics highly integration realizes the accurate series movements.

Touch panel : Graphical user interface is easy for setting. New added testing mode is easy for beginner.

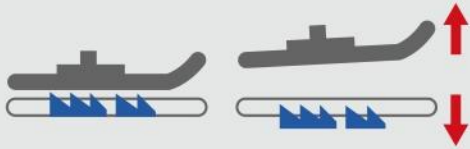

送带 / 切带功能

- 自动、手动、测试，三种操作模式。自动 / 手动换段，配备LED段数灯号
- 送带精准，以mm为单位设定送带长度
- 可调式前送带，延迟送带，倒带功能，前送带时可追加倒带之功能
- 送带速度补偿，10组默认值可供选择
- 因应实际车缝状况，车缝中可手动强制送带 / 倒带。车缝中遇失败，可自动 / 手动调整至原工程第一段
- 吹气送带功能

TAPE FEEDING / CUTTING

- 3 operation modes: Auto, Manual, and Test. Auto/ Manual section changing with LED indicate lamp.
- Precise feeding and the length setting unit is mm.
- Adjustable feeding of forward, delay, reverse, and forward feeding with reverse function.
- Speed compensation with 10 default values for choice.
- For different sewing situations, active feeding may be applied by forward/ reverse when sewing. If sewing operation failed, auto/ manual return to the first section of sewing program.
- Air blow tape feeding function.

设定 / 记忆功能

- 连续缝记忆组数：10组
- 工程段数：18段
- LCD面板显示设置状况、操作模式、错误代码

SETTING / MEMORY

- Memory of sewing program set: 10 sets
- Program section: 18 sections.
- LCD panel shows setting status, operation mode, and error code.





其他附属功能

- 松线功能
- 吸风切线之省风节能：起始 / 结束吸风时间可以调整（以针数计算）
- 回踩自动抬压脚功能

Additional Function

- Thread releasing
- Suction trimmer's energy saving: Starting/ Ending air suction's time is adjustable. (by stitch counting)
- Auto presser foot lifting by paddle step-back.

LFD6规格 / SPECIFICATION



连续缝记忆组数 Program set memory	10组 10 sets
每组连续缝工程段数 Sections of every program	18段 18 sections
送带距离/每针 Tape feeding length per stitch	0.2mm ~ 6.5mm
最高缝速(送距5mm时) Max. Speed (stitch length 5mm)	4200 R.P.M
编码器(定位器) Encoder (synchronizer)	48段脉波 48-pulse
送带马达 Tape feeding motor	五相步进马达 5-phase stepping motor
工作电压 Voltage	AC 110~220 V

选配 / OPTIONAL



▼ 适用非直驱型
Applicable to non-direct-drive type



Code	Description	Remark
LF-D6	短滚轮：适用16mm以下之松紧带 Short roller: for tape width 16 mm below	标配 Standard
LF-D6A	长滚轮：适用16mm~50mm之松紧带 Long roller: for tape width range 16mm~50mm	标配 Standard
LFA	电动式上送带装置 Electric tape feeding device (Voltage 110~ 220V)	选配 Optional
LF290-A□	抖带轮 □代表电压, 1: 110V, 2: 220V Euntangling wheel □=Voltage LFR-1: 110V, LFR-2: 220V)	选配 Optional
VT*	垂直式自动吸风切线 Vertical Pneumatic chain cutter	标配 Standard
TU*	空气控制阀/集尘装置 Dust collector suction device	标配 Standard
TSA-400	伺服马达, 含内置定位器 Servo motor with built-in synchronizer	选配 Optional

* 标准配备不列入机型名称

*Standard devices are not mentioned in model name.



RLK1

筒型撑开轮组

Tubular Extending Roller set



RLK2

筒型撑开轮组

Tubular Extending Roller set



RLK3

筒型撑开轮组

Tubular Extending Roller set



RLK3P

筒型撑开轮组

Tubular Extending Roller set

建議組合

Recommend Package

· TUA-38S(ST)

· DKH201ADE-A

· 700KS-T1-P



TUA-□□

吸风集尘组

Air Suction Device

開口型桌板專用吸風組 Opening Type Table Exclusive Suction Set					
	前/后吸 Front/ Rear Suction	抬押腳 Presser Foot Lifter	機械閥 Mechanical Air Switch	電磁閥 Solenoid Air Switch	兼容性 Compatibility
TUA-37S	√			單聯 Single way	700KS/ KST (Hohsing GD-40)
TUA-38S	√	√		雙聯 Double ways	700KS (Hohsing GD-40)
TUA-38ST	√	√ 大氣缸 Big cylinder		雙聯 Double ways	700KST (Hohsing GD-40)
TUA-39S	√		單聯 Single way		700KS/ KST
TUA-40S	√	√	雙聯 Double ways		700KS
TUA-40ST	√	√ 大氣缸 Big cylinder	雙聯 Double ways		700KST
TUA-41S	√	√		雙聯 Double ways	700KS/ESK (Hohsing i60)
TUA-41ST	√	√ 大氣缸 Big cylinder		雙聯 Double ways	700KST/RSK (Hohsing i60)

700KT SERIES FEATURES



700KT

高速上送包缝机

High Speed Top Feed Overlock Machine

延续700K系列之特点，增加新型独立驱动的上送具机构，延伸成为700KT系列。

- 缝距调整: 按钮式
- 差动比调整: 手杆式
- 润滑系统: 全自动

Succeeding 700K Series' features, we develop brand new independent-drive top feed mechanism, to extend to 700KST Series.

- Stitch Length Adjustment: Push-button
- Differential Feed Ratio Adjustment: Lever type
- Lubrication: Fully-automatic

700KT

一般包缝 General Sewing	737KT-504M-3-0□	1	3	-	4,5	0.7~2.0	1-6	3.2	5	#9	7000	VT	
	747KT-514M-3-2□	2	4	2	3,4,5	0.7~2.0	1-6	3.2	5	#11	6700	VT	
褶皱车缝 Shirring/ Gathering	747KT-514H-3-2□	2	4	2	3,4,5	0.7~2.0	1-8	3.2	6	#11	6300	VT,GA	
松紧带车缝 Tape Attaching	747KT-514H-4-2□	2	4	2	3,4,5	0.7~2.0	1-8	3.2	6	#11	6300	VT	
一般包缝 General Sewing	757KT-516M-3-3□	2	5	3	4,5	0.7~2.0	1-6	3.2	6	#14	6700	CT	
	757KT-516M-3-5□	2	5	5	5,6	0.7~2.0	1-6	3.2	6	#14	6700	CT	
松紧带车缝 Tape Attaching	757KT-516H-3-5□	2	5	5	5,6	0.7~2.0	1-7	3.2	7	#21	6300	CT,GA	
特厚布 Extra Heavy	757KT-516X-3-5□	2	5	5	6,7	0.7~2.0	1-7	3.2	8	#21	5500	CT	

OVERLOCK STITCH

700K 700QD 700Qe

747

K

-

514 M

2

-

2

4

/

VT / DKKU

线数

Thread numbers

737 : 3T

747 : 4T

757 : 5T

767 : 6T

送具型式

Feed dog type

针距

Needle gauge

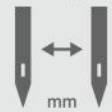

包边宽度

Overedge width



配件

Device

机种别

Model

K 一般型高速包缝/安全缝
General Type High Speed
Overlock/ Safety Stitch

QD 机电一体电眼型包缝/安全缝
Mechatronic Sensor type
Overlock/ Safety Stitch

Qe 机电一体经济型包缝/安全缝
Mechatronic Economic type
Overlock/ Safety Stitch

缝合方式

Sewing types

503

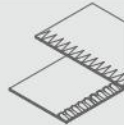

504

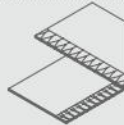

505

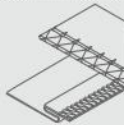

512

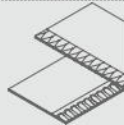

514

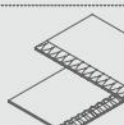

516

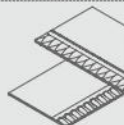

514

+

401

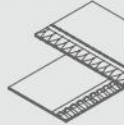

车缝布料

Sewing fabric

F 轻薄布料
Fine weight fabric

L 薄布料
Light weight fabric

M 中厚布料
Medium weight fabric

H 厚布料
Heavy weight fabric

X 特厚布料
Extra heavy weight fabric

直驱伺服马达

Direct-drive servo motor

DKKU1-0 节能定针型
Energy-saving needle-positioning type

DKKU1-1 电眼切刀型
Sensor controlled trimmer type



Energy saving 节能省电

Low temperature rising 温升低

Good insulation 绝缘良好

700K/DKKU1

700K 系列包缝机配备直驱伺服马达

Overlock machine with Direct-Drive Servo Motor



Feature 特点

1. 马力强，同时又节能省电
2. 温升低，安全绝缘良好
3. 与 700K 之规格与配件相容

1. Powerful while energy saving.
2. Low temperature rising, and safety with good insulation.
3. Compatible with 700K in specifications and accessories.

控制器 Controller	配件 Device	电眼切刀 Sensor Trimmer	抬压脚 Presser Foot Lifter	吸风集尘组 Air Suction Set	操作面板 Control Panel	针板 Needle Plate
DKKU1-0	700K 相容配件 700K Compatible device		选配 / Optional TUA-32K	选配 / Optional TUA-31, 32K		标准型 Standard
DKKU1-1	ECA-U	气动 Pneumatic	气动 Pneumatic	标配 Included	√	加长型 Long type
	ECB-U	电动 Electric	电动 Electric			
	VTE-U	吸风切线 Suction Trimmer	气动 Pneumatic			



700K SERIES FEATURES



密封式直接传动针棒专利机构

- 密闭针棒室，防尘防脏污渗入，避免漏油
- 缝制动能沿针棒运动方向直接传达，有效提升缝纫高速化及耐久性；避免连杆式针棒之传动耗损

Sealed type direct drive needle bar mechanism

- Dust free and oil-leakage-free are due to entirely sealed needle bar section design.
- Direct drive needle bar system leads to high speed and long durability. No driving loss of connecting-rod-drive needle bar system.



全新强制供油/回油及滤油系统

针棒，上勾针机构采用强制给油及全密闭式真空回油机构，完全排除以油线供油或滴落式供油产生问题

Active lubrication system

Needle bar and upper looper mechanisms are applied active oil supply and entirely sealed vacuum oil return system. The new system exceeds the traditional oil supply of rope type and dropping type.



专利双刮双唇式送具防漏设计

除双刮板外又新增双唇式刮板，阻油防油效果较原有双刮板设计效果更佳

Patented feed dog mechanism oil proof system

New double-lip type wiper is added to support the original double wiper. Oil proof function is upgraded.



直接传动式送具机构

直接传动可防止差动输送过度，缝纫更准确顺畅，不用调整差动齿，避免连杆式送具之传动耗损

Direct drive feeding mechanism

Direct drive mechanism prevents overdoing of differential feeding. No need to adjust the differential feed dog. No drive loss of connecting rod and type feeding mechanism.



新型切刀机构

刀座轴心低式设计，可防止面料回推现象，使面料切断时不会产生卷边现象

New fabric trimmer mechanism

Low axis knife holder prevents cloth rolls up after trimming.



专利一体化内藏式照明 (选购)

LED灯内藏一体化设计，穿线、目视操作方便，整体美观

Patented integrated built-in lighting (Optional)

- Integrated built-in LED light design is artistic and user friendly.



可选配专用送具车缝超薄布料

例如：D201 标准品齿距为1.6mm；D201A 选购品齿距为0.8mm；D201B 选购品齿距为1.0mm

Feed dog for extra light weight fabric (Optional)

E.g.: D201(standard):Teeth spacing 1.6mm；D201A(optional):Teeth spacing 0.8mm；D201B(optional):Teeth spacing 1.0mm



可选配短押具舌车缝厚布料或长押具舌车缝薄布料，让车缝线迹更加完美

Optional presser foot fingers for better sewing performance: short finger for heavy fabric, long finger for light fabric.

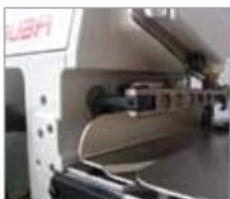

更多便于使用的特点...









- 免开盖针高调整，操作便利
- 下勾针座前后微调机构，维修省时简易
- 环缝微调机构，开后盖调粗细针，迅速省时
- 针板出线槽设计，包缝/环缝出线线圈更柔软完美
- 车头高度达5cm使进出布更加方便

More user friendly features:

- Needle bar height adjustment without opening machine.
- Lower looper holder fine tune mechanism.
- Chainstitch fine tune mechanism: Open the rear cover to adjust stitch length easily.
- Needle plate thread groove leads to perfect loop.
- 5 cm height sewing area offers better cloth movement.

K1

										Remark
				mm	mm	mm	mm	Noode No.	S.P.M. (Max)	
737K-503M2-04	1	3	-	4 -	0.7-2	3.6	6	DCX27#11	7500	A
737K-504F1-04	1	3	-	4 -	0.7-2	3.6	6	DCX27#11	7500	
737K-504M2-04	1	3	-	4 -	0.7-2	3.6	6	DCX27#11	7500	
737K-504M3-04	1	3	-	4 -	0.7-2	3.6	6	DCX27#11	7500	B
737K-504M3-05	1	3	-	5 -	0.7-2	3.6	6	DCX27#11	7500	B
747K-514F1-24	2	4	2	4 6	0.7-2	3.6	5.5	DCX27#11	7500	
747K-512M1-25	2	4	2	5 7	0.7-2	3.6	5.5	DCX27#11	7500	D
747K-512M1-34	2	4	3	4 7	0.7-2	3.6	5.5	DCX27#11	7500	D
747K-514M2-24	2	4	2	4 6	0.7-2	3.6	5.5	DCX27#11	7500	C
747K-514M2-25	2	4	2	5 7	0.7-2	3.6	5.5	DCX27#11	7500	C
747K-514M2-28	2	4	2	8 10	0.7-2	3.6	4	DCX27#11	7500	
747K-514M4-23	2	4	2	3 5	0.7-2	3.6	6	DCX27#11	7500	
757K-516L1-24	2	5	2	4 6	0.7-2	3.6	6	DCX27#14	7500	
757K-516L1-35	2	5	3	5 8	0.7-2	3.6	6	DCX27#14	7500	
757K-516M2-35	2	5	3	5 8	0.7-2	3.6	6	DCX27#14	7500	
757K-516M2-55	2	5	5	5 10	0.7-2	3.6	6	DCX27#14	7500	
767K-516M2-324	3	6	3+2	4 9	0.7-2	3.6	6	DCX27#11	7000	E
767K-516M2-524	3	6	5+2	4 11	0.7-2	3.6	6	DCX27#11	7000	E
737Qe-504F1-04	1	3	-	4 -	0.7-2	3.6	6	DCX27#11	7500	
737Qe-504M2-04	1	3	-	4 -	0.7-2	3.6	6	DCX27#11	7500	
737Qe-504M3-04	1	3	-	4 -	0.7-2	3.6	6	DCX27#11	7500	B
737Qe-504M3-05	1	3	-	5 -	0.7-2	3.6	6	DCX27#11	7500	B
747Qe-514F1-24	2	4	2	4 6	0.7-2	3.6	5.5	DCX27#11	7500	
747Qe-512M1-25	2	4	2	5 7	0.7-2	3.6	5.5	DCX27#11	7500	D
747Qe-512M1-34	2	4	3	4 7	0.7-2	3.6	5.5	DCX27#11	7500	D
747Qe-514M2-24	2	4	2	4 6	0.7-2	3.6	5.5	DCX27#11	7500	C
747Qe-514M2-25	2	4	2	5 7	0.7-2	3.6	5.5	DCX27#11	7500	C
747Qe-514M2-28	2	4	2	8 10	0.7-2	3.6	4	DCX27#11	7500	
747Qe-514M4-23	2	4	2	3 5	0.7-2	3.6	6	DCX27#11	7500	
757Qe-516L1-24	2	5	2	4 6	0.7-2	3.6	6	DCX27#14	7500	

										Remark
757Qe-516L1-35	2	5	3	5 8	0.7-2	3.6	6	DCX27#14	7500	
757Qe-516M2-35	2	5	3	5 8	0.7-2	3.6	6	DCX27#14	7500	
757Qe-516M2-55	2	5	5	5 10	0.7-2	3.6	6	DCX27#14	7500	
767Qe-516M2-324	3	6	3+2	4 9	0.7-2	3.6	6	DCX27#11	7000	E
767Qe-516M2-524	3	6	5+2	4 11	0.7-2	3.6	6	DCX27#11	7000	E



737K-504M3-04



747K-514M2-24



757K-516M2-35



767K-516M2-324



504



514



512



516



401+514

一般包缝

适用于特薄至中厚布料之包缝

GENERAL SEAMING

For regular seaming on light to medium fabric.



Remark

- A: 上勾针为盲勾针
- B: 单排送具
- C: 适用于薄至中厚布料之包缝
- D: 用于薄至中厚布料之一般缝合(假五线)
- E: 适用于薄至中厚布料之一般缝合, 适合小量生产的打样室或工作室选用, 可由勾针及针之变换车缝出5种不同的缝合方式 (504, 514, 516, 401, 514+401)

- A: Upper looper is blind looper
- B: Single row feed dog
- C: For regular seaming on light to medium fabric.
- D: Mock 516 seaming
For regular seaming on light to medium fabric.
- E: For regular seaming on light to medium fabric.
Specially suitable for small production workshop, and fashion design studio. A variety of five different sewing types by changing number of needle and looper. (504, 514, 516, 401, 514+401).

选购配件 OPTIONAL DEVICE

VT, CSA, CSB, TUB

K2

													Remark
737K-504F2-02/GAL	1	3	-	2	1	-	0.7-2	3.6	5.5	DCX27#9	7500	A	
737K-504F1-15	1	3	-	1.5	1	-	0.7-2	3.6	5.5	DCX27#9	7500	B	
737K-504M1-15	1	3	-	1.5	1	-	0.7-2	3.6	6	DCX27#9	7500	C	
737Qe-504F2-02/GAL	1	3	-	2	1	-	0.7-2	3.6	5.5	DCX27#9	7500	A	
737Qe-504F1-15	1	3	-	1.5	1	-	0.7-2	3.6	5.5	DCX27#9	7500	B	
737Qe-504M1-15	1	3	-	1.5	1	-	0.7-2	3.6	6	DCX27#9	7500	C	



737K-504F2-02/GAL



737K-504F1-15



737K-504M1-15



A

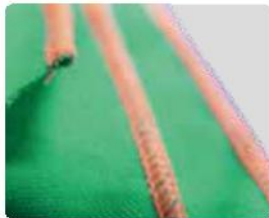

B



C



Remark

细包缝











- A. 适用于特薄布料之卷边细包缝 (荷叶边) 例如: 手帕, 礼服等
- B. 适用于特薄布料之卷边细包缝 (手帕边包缝) 例如: 丝绸类布料之手帕, 礼服等
- C. 适用于薄至中厚布料之细包缝 (手帕边包缝) 例如: 手帕, 礼服等

FINE EDGING

- A. For fine edging on extra light knit fabric. The presser foot is with fine folding function. (falbala edging)
Eg: Handkerchief & dress...etc.
- B. For fine edging on extra light knit fabric. The presser foot is with fine folding function. (handkerchief edging)
Eg: Handkerchief & dress of silk fabric...etc.
- C. For fine edging on light to medium fabric. (handkerchief edging)
Eg: Handkerchief & dress ...etc.

选购配件 OPTIONAL DEVICE
VT, CSA, CSB, TUB

K3

										
747K-514M2-24/TG	2	4	2	4 6	0.7-2	3.6	6	DCX27#11	7500	
747K-514M2-25/TG	2	4	2	5 7	0.7-2	3.6	6	DCX27#11	7500	
747Qe-514M2-24/TG	2	4	2	4 6	0.7-2	3.6	6	DCX27#11	7500	
747Qe-514M2-25/TG	2	4	2	5 7	0.7-2	3.6	6	DCX27#11	7500	



747K-514M2-24/TG/EC



肩带包缝

适用于针织衣服如T恤, 毛衣等之肩部多车一条织带,可防止衣服肩部变形









TAPE INSERTING

For sewing a woven tape onto the shoulder of knitwear such as T-shirt or sweater etc., to prevent abnormal stretching.



选购配件 OPTIONAL DEVICE
EC, LFA, LS

K4

										
737K-505F1-04	1	3	-	4 -	0.7-2	3.6	6	DCX27#9	7500	
737Qe-505F1-04	1	3	-	4 -	0.7-2	3.6	6	DCX27#9	7500	



737K-505F1-04



拷下摆

用于特薄至薄布料之针织T恤, 内衣等之下摆或袖口拷缝

BLIND HEMMING

For hemming sleeves and bottoms of T-shirts or underwear etc. Applicable for light to extra light fabric.

特殊效果 : 上勾针改用LP231盲勾针, 可以露出针线

Special effect : replace upper looper by blind looper, LP231, the needle thread can be shown on the surface.



选购配件 OPTIONAL DEVICE
VT, CSA, CSB, TUB

K5



737K-504M2-04/LFC-3	1	3	-	4 -	0.7-2	3.6	6	DCX27#11	7000
747K-514M2-2□/LFC-3	2	4	2	4/5 6/7	0.7-2	3.6	6	DCX27#11	7000
747K-514M2-2□/ SMK	2	4	2	4/5 6/7	0.7-2	3.6	6	DCX27#11	7000
737K-504M2-04/TR	1	3	-	4 -	0.7-2	3.6	6	DCX27#11	7500
737Qe-504M2-04/TR	1	3	-	4 -	0.7-2	3.6	6	DCX27#11	7500



747K-514M2-24/ SMK



747K-514M2-24/LFC-3



737K-504M2-04/TR



LFC-3



TR



松紧带车缝

利用送带装置控制松紧带之张力,适用于泳衣,内衣裤或运动服饰之松紧带包缝

LFC-3: 机械式送带

多样的压脚可供选择

SMK: 电子计数式送带

SMK1-A-01 附定位器, 适合简易伺服或离合器马达

SMK1-A-02 以中继线, 连接伺服马达

ELASTIC ATTACHING

Tape feeding device controls the tension. Applicable to swimming wear, underwear, sports wear's elastic band attaching.

LFC-3: Mechanic type elastic tape feeding various presser foots for optional demand.

SMK: Electric metering type elastic tape feeding

SMK1-A-01 with synchronizer for simple servo motor or clutch motor

SMK1-A-02 Connected to servo motor by encoder cable

	押具 Presser foot	松紧带宽度 Band width	备注 Remark
737K	P216-3	2mm~13mm	标配 Standard
747K	P216-4	2mm~13mm	标配 Standard
	P217-4	Max. 20mm	选配 Optional
	P218-4	Max. 30mm	选配 Optional
	P219-4	Max. 35mm	选配 Optional

TR:简易松紧带车缝(浴帽车缝)

利用弹簧片调整,控制松紧带之鬆紧程度,可简易进行松紧带之包缝,适用于不织布,塑胶布等浴帽或医疗用衣物

例如: 浴帽,医疗用衣物等

TR:SIMPLE ELASTIC ATTACHING

For attaching elastic tape on non-woven or plastic cloth. The tension is controlled by spring.

Eg: Shower cap, medical clothing...etc.

选购配件 OPTIONAL DEVICE
EC, LFA, LS

K6

747K-514H4-24/GA	2	4	2	4	6	0.7-2	3.2	5.5	DCX27#11	7500	
747Qe-514H4-24/GA	2	4	2	4	6	0.7-2	3.2	5.5	DCX27#11	7500	
757K-516H4-35/GA	2	5	3	5	8	0.7-2	3.6	6	DCX27#14	7000	
757K-516H4-55/GA	2	5	5	5	10	0.7-2	3.6	6	DCX27#14	7000	
757Qe-516H4-35/GA	2	5	3	5	8	0.7-2	3.6	6	DCX27#14	7000	
757Qe-516H4-55/GA	2	5	5	5	10	0.7-2	3.6	6	DCX27#14	7000	



747K-514H4-24/GA



757K-516H4-35/GA/CT



GA



GA/CT

摺景车缝

适用中厚布料下层布间歇或连续性不规则摺景车缝,可加滚边喇叭增加车缝品质如裙子,床罩,窗帘等.
注: P布条滚边喇叭 (入布宽度25mm, 出布宽度6mm)



GATHERING

Continuous or intermittent random gathering on lower ply of medium fabric, can be equipped with piping folder to increase sewing quality for shirt, bed sheets, curtains etc.
Remark : P: Piping folder (tape width 25mm, finished size 6mm)

选购配件 OPTIONAL DEVICE
EC . P(KV57-A) , FG , VT , CT , CSA , CSB , TUB

K7

											
手动 Manual	737K-504M5-04/BK(BK-1)	1	3	-	4	0.7-2	3.6	6	DCX27#11	7000	
	747K-514M5-2□/BK(BK-1)	2	4	2	3,4	0.7-2	3.6	6	DCX27#11	7000	
	747K-514M7-2□/BK(BK-1)	2	4	2	4,5	0.7-2	3.6	7	DCX27#11	7000	
	737Qe-504M5-04/BK(BK-1)	1	3	-	4	0.7-2	3.6	6	DCX27#11	7000	
	747Qe-514M5-2□/BK(BK-1)	2	4	2	3,4	0.7-2	3.6	6	DCX27#11	7000	
	747Qe-514M7-2□/BK(BK-1)	2	4	2	4,5	0.7-2	3.6	7	DCX27#11	7000	
半自动 Semi-Auto	747Qe-514M5-23/BKS	2	4	2	3	0.7-2	3.6	6	DCX27#11	7000	
	747Qe-514M7-2□/BKS	2	4	2	4,5	0.7-2	3.6	7	DCX27#11	7000	
简易式全自动 Simplified Fully Auto	737QD-504M5-04/ECB/BKT	1	3	-	4	0.7-2	3.6	7	DCX27#11	7000	
	747QD-514M2-24/ECB/BKT	2	4	2	4	0.7-2	3.6	7	DCX27#11	7000	
全自动 Fully Auto	737K-504M5-0□/BKF	1	3	-	3,4,5	0.7-2	3.6	7	DCX27#11	7000	
	747K-514M5-2□/BKF	2	4	2	3,4	0.7-2	3.6	7	DCX27#11	7000	



737K-504M5-04/BK



747Qe-514M5-23/BKS



747QD-514M2-24/ECB/BKT



747K-514M5-23/BKF



线头包缝

将线头包入车缝线内,可防止缝合之开口处缝线脱落,适用于内衣裤,运动服之袖口及侧边缝合

注1: 针线放松, 并调整导布器, 可以有露出直线的特殊效果

注2: 上勾针改用LP231盲勾针, 可以改为2线包缝

BACK LATCHING SEAMING

To prevent seam looseness, turn over the thread and then insert into overlock seaming at the beginning of sewing. For sleeve and sideways sewing of underwear, sportswear etc.

Remark 1: Reduce needle thread's tension, and adjust fabric guide to get the special outlook showing the needle thread on top side.

Remark 2: Replace upper looper by blind looper LP231 to make 2-thread overlock stitch

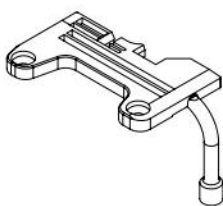
操作 Operation	配件代号 Code	说明 Description	适用机头 Applicable Series	驱动方式 Drive Type
手动 Manual	BK	Rotary Plate 	737K 747K 737Qe 747Qe	建议搭配伺服马达, 使用定针功能, 提升车缝效率 To equip with servo motor for needle position function is optional and recommended.
	BK-1	Fixed Plate 		
半自动 Semi-Auto	BKS	4线拷克专用, 针板舌自动伸缩 4 Thread overlock applicable, Needle plate tongue Auto-retracted	747K 747Qe	脚踏板气阀控制 气动式 Padel valve control Pneumatic type
简易式全自动 Simplified Fully Auto	BKT	1. 简易式, 线头长度约3cm 2. ECA切刀, 针板有特殊风道设计, 线头向下吸回 1. Simplified type, back latch length 3cm. 2. With ECA cutter, Needle plate suction channel for thread-end down turning . 	737QD 747QD	700QD电控系统 气动式 700QD Control system Pneumatic type
自动 Fully Auto	BKF	1. VT吸风切线, 2. 可设定多种操作模式 3. 线头侧向吹回, 长度可以调整 (最短1cm) 1. With VT suction trimmer, 2. Multi-operation mode setting 3. Thread-end side turning. Back latch length is adjustable (Min. 1cm)	737K 747K	贺欣 i70直驱马达 气动式 Hohsing i70 Servo Motor Pneumatic type



747K-514M7-24	2	4	2	4 6	0.7-2	3.6	7	DCX27#16	7500
747K-514M7-25	2	4	2	5 7	0.7-2	3.6	7	DCX27#16	7500
757K-516X2-56	2	5	5	6 11	0.7-2	3.6	6	DCX27#18	7500
747K-514M7-24/TG	2	4	2	4 6	0.7-2	3.6	7	DCX27#16	7500
747K-514M7-25/TG	2	4	2	5 7	0.7-2	3.6	7	DCX27#16	7500
747Qe-514M7-24	2	4	2	4 6	0.7-2	3.6	7	DCX27#16	7500
747Qe-514M7-25	2	4	2	5 7	0.7-2	3.6	7	DCX27#16	7500
747Qe-514M7-24/TG	2	4	2	4 6	0.7-2	3.6	7	DCX27#16	7500
747Qe-514M7-25/TG	2	4	2	5 7	0.7-2	3.6	7	DCX27#16	7500



747K-514M7-24



747K-514M7-24/TG/EC



757K-516X2-56



TG/EC

厚毛衣料肩带包缝

适用于毛衣之肩部多包缝一条平织布条,可防止衣服肩部变形
注:布条装置之导板使用,布条最大宽度为1/4" (6.35mm)

TAPE INSERTING ON BULKY KNITWEAR

For sewing a woven tape onto the shoulder of knitwear such as sweater, to prevent abnormal stretching.
Remark: Max. width of tape is 1/4"(6.35mm)

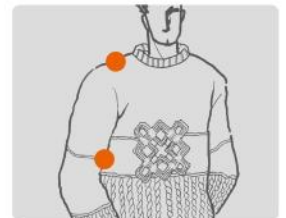

TG/EC 选购配件 OPTIONAL DEVICE

EC, AN, LFA, LS



514M7

厚毛衣料包缝

适用于粗厚毛线衣物车缝

OVER SEAMING ON BULKY KNITWEAR

For regular seaming on bulky knit fabric such as sweater.

514M7 选购配件 OPTIONAL DEVICE

AN, CT, CSA, CSB, TUB



516X2

薄牛仔包缝

特殊传动行程结构适用于薄牛仔布料之包缝,例如:牛仔布 & 工作服

LIGHT DENIM OVERLOCK

Special driving mechanism for seaming on light denim fabric such as jeans, workwears etc.



516X2 选购配件 OPTIONAL DEVICE

CT, CSA, CSB, TUB

K9

757K-516M2-35/PS	2	5	3	5 8	0.7-2	3.6	6	DCX27#14	7000	
757K-516M2-55/PS	2	5	5	5 10	0.7-2	3.6	6	DCX27#14	7000	
757K-401M2-50/TA	2	4	5	- -	0.7-2	3.6	6	DCX27#14	7000	
757Qe-516M2-35/PS	2	5	3	5 8	0.7-2	3.6	6	DCX27#14	7000	
757Qe-516M2-55/PS	2	5	5	5 10	0.7-2	3.6	6	DCX27#14	7000	
757Qe-401M2-50/TA	2	4	5	- -	0.7-2	3.6	6	DCX27#14	7000	



757K-516M2-35/PS



757K-401M2-50/TA

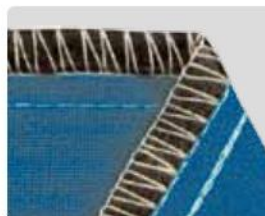

PS



TA

口袋边包缝

/PS在裤袋边缘多上一包边布条,以强化缝合处,增加美观

注:标准喇叭之入布宽度为3/8" (9.5mm)

/TA 双勾针机型,适用于裤袋边缘加包边布条,并车缝两道环缝线以强化缝合处增加美观

注:标准喇叭(入布宽度25.4mm/出布宽度6.4mm)



POCKET BINDING

/PS To insert an extra tape to cover on the edge of pocket then by safety stitching for strengthening the pocket seaming. Suitable for high quality trousers.

Remark : Standard folder for tape width is 3/8" (9.5mm)

/TA Two needle two chainstitches. Tape binding by two chainstitch on the edge of pocket of high quality trousers.

Remark : Standard folder (tap width 25.4mm/finish width 6.4mm)

选购配件 OPTIONAL DEVICE

EC . FG

K10



737K-WR/LFC-3	1	3	-	-	1	-	-	-	-	DCX27#11	7500
737K-504M3-05/PZ	1	3	-	5	1	-	0.7-2	3.6	6	DCX27#14	7500
757K-401M1/TW	1	2	-	-	1	-	0.7-2	3.6	5.5	DCX27#14	7000
737Qe-504M3-05/PZ	1	3	-	5	1	-	0.7-2	3.6	6	DCX27#14	7500
757Qe-401M1/TW	1	2	-	-	1	-	0.7-2	3.6	5.5	DCX27#14	7000



737K-WR/LFC-3



737K-504M3-05/PZ



757K-401M1/TW



LFC-3

管状布条车缝

将针织布条拷边车缝后再反条成管形,适用于各种泳装,睡衣或韵律服等管状肩带
注: 标准喇叭之布条入布宽度22mm(7/8") 成型之管状布条直径为5mm

SPAGHETTI SEWING

To sew knit fabric tape and turn over it into spaghetti tube for swimwears, nightgowns etc...
Remark: Standard folder specification: tape width is 22mm (7/8") and the finished tube size is about 5mm in diameter.



选购配件 OPTIONAL DEVICE
FG



PZ

拉链包缝

适用于薄布料之拉链包缝,可将拉链与衣身裁片同时包缝

ZIP SEAMING

For regular seaming for zipper with light fabric.

选购配件 OPTIONAL DEVICE
VT, CSA, CSB, TUB

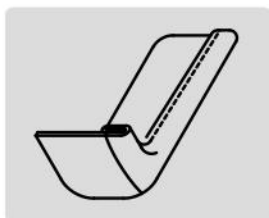

TW

毛巾布边车缝

本机为单针单勾针机型,适用于毛巾布边之车缝

TOWEL EDGING

This is a single needle, single looper machine, suitable for towel sewing.

选购配件 OPTIONAL DEVICE
CT, CSA, CSB, TUB

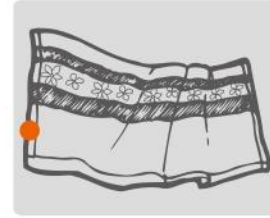

ALL NEW

机电一体新纪元

MECHATRONICS



700QD | Series

机电一体型包缝机

Mechatronic Overlock Stitch Machine



特点 / Feature



■ 机电整合一体 / MECHATRONICS

[专利] 全球首创，将电控部分（伺服马达、电控箱、电源开关），完全整合於缝纫机中，700QD 升级版并支援多种自动化选配功能，化繁为简的精湛工艺。

[Patent] The first and only design in the world, which completely integrates the electric portion (servo motor, control box, and power switch) into overlock machine. 700QD advanced version is compatible to optional automatic devices that bring complex design to simple formation.

更平衡、更稳定、更强劲 / MORE BALANCED, STABLE AND POWERFUL

SIRUBA 采用强劲的伺服马达，内嵌於机身中，理想的重心配置，使机体更平衡，百分之百的动力传递。

The new SIRUBA technology embedded the powerful servo motor into the main body. Due to the nice weight allocation, the machine is more balanced. The power transmission is completely performed.

更精准、更可靠的定针功能 / MORE PRECISE AND RELIABLE NEEDLE POSITIONING

SIRUBA 独有之内藏式定位器再进化！定位 IC 整合封包於马达中，更精准的感应，讯号传递零误差。省却旧有的讯号线连接方式，排除了各介面间之传导不良风险，贯彻系统整合之设计精神。

The SIRUBA's exclusively built-in synchronizer is now more evolved! The locator IC is integrated and sealed inside the motor which makes sensing more precisely and signal transmission with zero error. Such improvement omits the old way of signals connection, eliminates the possibility of transmission defects between interfaces, and implements system integrative spirit of design throughout.

动力系统与供油系统完美结合 / PERFECT COMBINATION OF THE POWER SYSTEM AND THE OIL SUPPLY SYSTEM

[专利] 内嵌於机身内的马达，连结优异的传动系统，巧妙地将动能分流至供油系统。模组化的油路系统，简化了生产组装及使用保养的工作，排除人为失误的可能性。

[Patent] The embedded motor which joints the outstanding transmitting system, skillfully divides the power to drive the oil supply system. Modularized oil lubrication system simplifies the assembly and user maintenance works, therefore eliminates the possibility of man-made error.

■ 针棒强制供油及回油系统 / NEEDLE BAR PORTION ACTIVE LUBRICATION SYSTEM

针棒机构零件采用强制供油之方式确保供油稳定零件不磨损，针棒轴承下方采用全封式强制回油机构，确保针棒上下运动油膜渗漏之情形。



The needle bar mechanism adopts the compulsory oil-supplying to ensure the high speed movement. The needle bar lower position equipped with the compulsory oil-returning to ensure the perfect oil control status.

整合式滤油、供油、回油系统

透过全新设计之整合式滤油，供油，回油之系统，不但组装容易，强制供油系统，确保缝纫机高速车缝时之机件润滑，强制回油确保开放空间之机件不会漏油渗油，确保车缝品质。

INTEGRATED OIL-FILTERING, OIL-SUPPLYING AND OIL RETURNING SYSTEM

The newly designed integrated oil-filtering, oil-supplying, and oil-returning system is easy for assemble and maintenance.

体贴人心的设计 / THE HUMANE DESIGN SYSTEM

700QD 整合机器、电机和电控箱，节能省电 60%。配备电眼感应器，从起动、车缝、停车、抬压脚、吸线头和布屑，可全程自动化连续动作，提高生产效率 30-60%，降低劳动强度 30%。

700QD integrates machine, motor and control box, which realize 60% energy-saving. With high-precision sensor, automatic operation from starting, sewing, stopping, presser foot lifting, and vacuuming, which increases production efficiency by 30~60%, and labor saving by 30%.

LED 灯 / LED LIGHT

采用最新节能 LED 设计，微小耗电量几乎可忽略不计，并可依作业条件，调节亮度。
With the energy saving LED design, the power consuming is very few. The brightness is adjustable.

气动抬压脚 / PNEUMATIC PRESSER FOOT LIFTER

可切换自动和手动模式，以气缸进行抬压脚，降低工人劳动强度。
The pneumatic presser foot lifter is switchable as Auto/ Manual mode, which helps labor-saving.

多种车缝模式 / MULTI OPERATION SEWING MODE

自动、半自动、手动模式，能适应各种不同类型的成衣厂及车缝工艺的要求，自动及半自动模式可进行自动切线动作，手动模式下可进行手动或膝动切线功能。

With the sewing mode by auto, semi-auto, and manual, it meets the demands of various garment factories. With auto and semi-auto mode, the cutter operates automatically. With manual mode, operator makes the cutting easily by pressing the button.



安全开关 / SAFETY SWITCH

当打开压脚，进行维修、穿线等作业时，安全开关确保机器无动作，避免误踩踏板而发生危险。
During maintenance or threading, and presser foot is not ready, machine is stopped by safety switch.

精密的电眼感应器 / HIGH-PRECISION SENSOR

采用专业的进口红外线感应器，透由感应器来执行切线、吸线头、吸布屑的动作与时机，减少系统出现误判的几率。

With high-precision sensor, the process of cutting and vacuuming can be done at good timing without mistake.

剪线功能 / TRIMMING FUNCTION

多样化切线模式 (ECA, ECB, VTE, CTE)，适合各种不同的工艺要求，并提升效益。
Various modes (ECA, ECB, VTE, CTE) of trimming increase the efficiency of various garment sewing.

专业稳定的电控系统 / STABLE COMPUTER CONTROL SYSTEM

搭配专业、稳定的台达电控，并透由精准的回路控制，适用于丝网布、丝光棉等各种特殊面料的车缝，不会由於面料之特殊导致系统误判而出现乱下刀动作。

With the stable computer control system, special materials, such as mesh cloth or mercerized cotton, can be detected very well, and incorrect cutting does not happen.

吸布屑及吸线头装置 / VACUUM DEVICE

将多馀的布屑及线头吸到布袋里，使得工作环境更加乾淨、舒适及环保。
Vacuuming the waste of fabric and thread makes the working environment clean and comfortable.

切刀动作保护装置 / RISK-FREE CUTTING SYSTEM

切刀侧边有保护装置－对射感测器，如果感测器处有物体遮挡，则切刀无动作，杜绝了系统误判导致切线动作切烂缝布，同时也可防止工人误操作，把手伸到切刀下方，导致安全事故发生。

With the beam sensor nearby the cutter, when the sensor is blocked, the knife will not drop, which ensures operator's safety and avoids fabric's incorrect cutting.

涡流式手轮吸风系统 / VORTEX HAND-WHEEL AIR SUCTION SYSTEM

手轮内设置涡流叶片，利用马达运转时吸入空气，直接冷却马达与电控箱。
When the motor runs, the built-in vortex fan gets the air to cool down the motor and the control box.

700QD 与 700K 之配件相容，700QD 另有专用的电眼型配件如下：
 700QD is compatible to 700K's device. And the new devices as below:

ECA
ECB



CTE
VTE



ECA

气动式切刀
PNEUMATIC TYPE TAPE/THREAD CUTTER

ECB

电动式切刀
SOLENOID TYPE TAPE/ THREAD CUTTER

SIRUBA的EC切刀装置再进化！省去原有的控制箱，由700QD功能强大的电控系统控制切刀动作，实现「单机自动化」的技术境界。先进的电眼在检测到车缝完毕时，精准下刀零时差。ECA为气动式，ECB为电动式，搭配吸风线槽，操作更顺畅。

- 1.手动、半自动及全自动操作模式,附转换按键,且可透过操作面板调整。
- 2.防误切保护装置:切刀旁安装一电眼,如有被遮挡的状况下,切刀不会动作,能有效地防止切刀误切到布料。
- 3.手动切线补偿按键,如因操作问题没有切断线,可透由此按键进行手动切线。
- 4.手动模式下,可後踩踏板切线。
- 5.针对网纱、强反光丝光棉等特殊面料,采用专业的电控程式控制,均能轻松车缝及完成切线,不会造成切刀误切。



SIRUBA's re-evolution on EC device! Eliminating the control box and driven by the powerful computerized system to control the cutting movements is an implementation of "single machine automation" concept. Advanced sensor inspects the completion of sewing work and initiates cutting without time lag. ECA is pneumatic type, and ECB is electric type, compatible with air suction slot, which makes the operation more smoothly.

- 1.Manual, semi-auto and fully-auto operation mode, attached the switch keys, and could be adjusted by the panel.
- 2.Mistake-proof protection device: One sensor equipped near the trimmer. If the sensor is blocked, the trimmer is deactivated effectively for avoiding from cutting the fabric.
- 3.Manual trimming compensation stitch key: If the thread is not cut due to the operation, it can be done by the key.
- 4.Under the manual mode, it could be fully backward pedaled to cut the thread.
- 5.For those special fabrics such as mesh fabric, mercerized cotton etc, the stitches are easily accomplished as well as the trimming by the professional computer controlled without mistake-trimming.

	双电眼 Dual Sensor	切刀 Cutter	气动配件 Pneumatic Set			备注 Remark
			抬押脚 Foot Lifter	吸风集尘组 Suction Set	吸风线槽 Suction Channel	
ECA	V	气动 Pneumatic	V	V	V	全功能 Full Function
ECB	V	电动 Electric	V	V	V	全功能 Full Function
ECE	V	电动 Electric		X		经济型 Economic

ECE适用: 无空压设备之成衣厂, 或短裁片不抬押脚连续车缝作业。

ECE Applicable for: Garment factory without air compressor, or Continually short sewing operation without presser foot lifting.

CTE

水平式
FLAT TYPE

VTE

垂直式
SIDE TYPE

吸风切线(附电眼节能装置)
SUCTION CHAIN-CUTTER (WITH SENSOR-CONTROLLED ENERGY-SAVING DEVICE)



700QD电控系统支援电眼节能装置, 采用电眼侦测布边, 利用控制箱调整按键, 控制吸风功能在切线时运作, 减少空压设备的能源消耗, 并避免缝线浪费。

700QD's computerized system drives sensor-controlled energy saving device. Electric eye (sensor) checks the fabric edge. Turn the button of control box to set the time of air suction of chain-cutter. It saves the energy consuming of air compressor system and also saves thread consuming.

- 1.垂直式吸风切线适合内裤厂等轻薄及不规则的针织面料车缝,提升效率。
- 2.切刀之吸风口的的设计使得切线更加快速。
- 3.针对网纱、强反光丝光棉等特殊面料,采用专业的电控程式控制,均能轻松车缝及完成切线,不会造成切刀误切。
- 4.气动抬压脚,使得压脚抬升更加轻松,降低工人劳动强度。
- 5.三合一集尘组,吸线头、吸布屑及吸尘三种功能。
- 6.附小型操作面板,目前市场所需求之功能基本满足。
- 7.«切线後自动停车功能»以及«无面料即不车缝功能»可减少缝线的浪费。

- 1.Vertical suction trimming is suitable for sewing the light fabric like under-wear or irregular knitwear, to improve the efficiency.
- 2.The design of the suction inlet of the trimmer makes the trimming faster.
- 3.For those special fabrics such as mesh fabric, mercerized cotton etc, the stitches are easily accomplished as well as the trimming by the professional computer controlled without mistake-trimming.
- 4.Pneumatic presser foot lifter easily to arise the presser foot saves the operators' time and energy.
- 5.3 in 1 dirt collection combination with the 3 functions, including suction thread, waste fabric and the dirt.
- 6.Attached with the small panel to satisfy the basic function demanded by the market.
- 7.Functions with auto stop sewing after trimming and with no fabric can save the stitches.

ECA.ECB.ECE.CTE.VTE等功能可搭配以下針位組

The following specifications are optional with ECA.ECB.ECE.CTE.VTE

700QD

737QD-504F1-04	1	3	-	4	-	0.7-2	3.6	6.0	#11	7500
737QD-504F1-15	1	3	-	1.5	-	0.7-2	3.6	5.5	#9	7500
737QD-504M1-15	1	3	-	1.5	-	0.7-2	3.6	6.0	#9	7500
737QD-504M2-04	1	3	-	4	-	0.7-2	3.6	6.0	#11	7500
737QD-505F1-04	1	3	-	4	-	0.7-2	3.6	6.0	#9	7500
737QD-504M3-04	1	3	-	4	-	0.7-2	3.6	6.0	#11	7500
737QD-504M3-05	1	3	-	5	-	0.7-2	3.6	6.0	#11	7500
747QD-512M1-25	2	4	2	5	7	0.7-2	3.6	5.5	#11	7500
747QD-512M1-34	2	4	3	4	7	0.7-2	3.6	5.5	#11	7500
747QD-514F1-24	2	4	2	4	6	0.7-2	3.6	5.5	#11	7500
747QD-514M2-24	2	4	2	4	6	0.7-2	3.6	5.5	#11	7500
747QD-514M2-25	2	4	2	5	7	0.7-2	3.6	5.5	#11	7500
747QD-514M2-28	2	4	2	8	10	0.7-2	3.6	4.0	#11	7500
747QD-514M4-23	2	4	2	3	5	0.7-2	3.6	6.0	#11	7500
747QD-514M7-24	2	4	2	4	6	0.7-2	3.6	7.0	#16	7500
747QD-514M7-25	2	4	2	5	7	0.7-2	3.6	7.0	#16	7500
757QD-401M1/TW	1	2	-	-	-	0.7-2	3.6	5.5	#14	7000
757QD-401M2-50/TA	2	4	5	-	-	0.7-2	3.6	6.0	#14	7000
757QD-516L1-24	2	5	2	4	6	0.7-2	3.6	6.0	#14	7500
757QD-516L1-35	2	5	3	5	8	0.7-2	3.6	6.0	#14	7500
757QD-516M2-35	2	5	3	5	8	0.7-2	3.6	6.0	#14	7500
757QD-516M2-55	2	5	5	5	10	0.7-2	3.6	6.0	#14	7500
757QD-516M2-35/PS	2	5	3	5	8	0.7-2	3.6	6.0	#14	7000
757QD-516M2-55/PS	2	5	5	5	10	0.7-2	3.6	6.0	#14	7000
767QD-516M2-324	3	6	3+2	4	9	0.7-2	3.6	6.0	#11	7000
767QD-516M2-524	3	6	5+2	4	11	0.7-2	3.6	6.0	#11	7000

700Qe SERIES FEATURES



700Qe

机电一体高速型包缝机

Mechatronic High Speed Overlock Stitch Machine

机电一体再提升

Qe 延续 Q 型的精简设计，配备更强力的马达，实现 7500 RPM 的高速车缝。

7500 转！

THE UPGRADED MECHATRONICS

Qe succeeds the compact design from Q Series. Equipping more powerful motor, 700Qe realizes high speed sewing by 7500 RPM.

广泛的车缝应用

700Qe 与 700K 型的规格组和配件相容，提供完整的包缝工段应用。

A WIDE RANGE OF SEWING APPLICATIONS

The gauge sets and devices of 700Qe are compatible with 700K, which provides a wide range of overlock sewing applications.

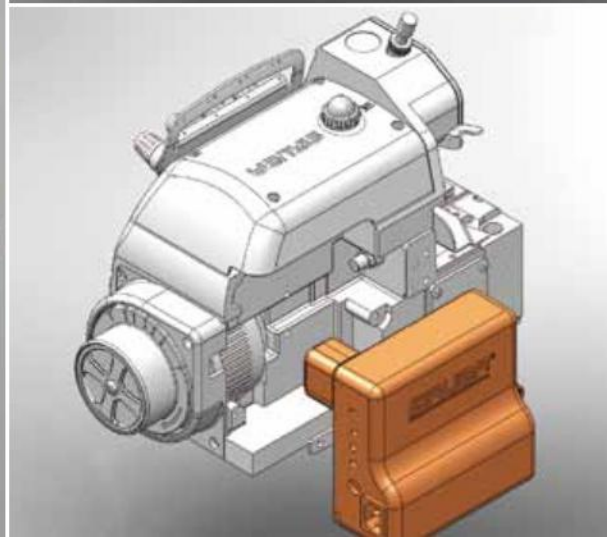
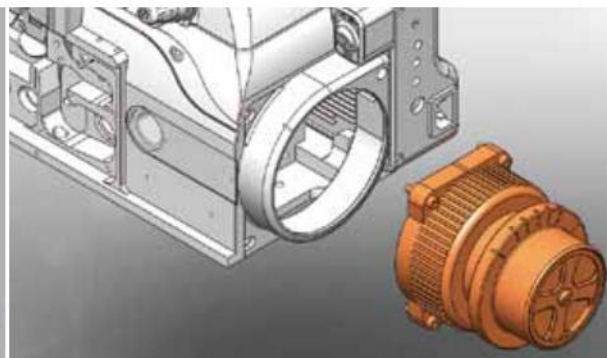

DEVICE



AN

角刀 Angle Knife

修布辅助, 对于厚料之修布更顺畅
Cloth trimming assistance to heavy material.

可自行组装 self-installation : YES
适用机型 applicable model : 747K-514M7, 747Qe-514M7

BK
BK-1

包线头装置 Back Latching

将线头一起包入车缝, 可防止缝合开口处(如袖口)之缝线脱落
. KD207手轮: 订机头有装此零件以配合定针用, 若个别订购BK组则依需要订购
. 包含BK232车布导板

To prevent seam looseness, turn over the thread and then insert into overlock seaming at the beginning of sewing.

. KD207 hand wheel: standard equipment of 700K/BK machine, optional for BK device.
. Including BK232 sewing bed .

可自行组装 self-installation : YES
适用机型 applicable model : 737K-504M5, 747K-514M5, 747K-514M7
737Qe-504M5, 747Qe-514M5, 747Qe-514M7

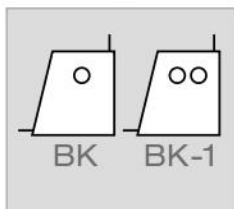

BKS

半自动包线头系统 Semi-Automatic Back Latch System

700Qe电控系统, 精准抬压脚, 松线, 与控制针板舌动作, 线头包缝起点紧密牢固不松脱, 实现高品质的缝制需求。



700Qe's computerized system precisely controls the movements of presser foot, thread releasing, and needle plate tongue. It makes the tight starting and achieves the requirement of sewing high quality.

可自行组装 self-installation : YES
适用机型 applicable model : 747Qe-514M5, 747Qe-514M7



CSA

铁桶式吸风马达 Iron Case Suction Device

1. 双吸马力足(前后吸), 连接在车头上比同类马达大1/4的马力(后吸为切刀, 前为漏斗式吹气)
2. 噪音低, 可比同类马达降低 5dB
3. 温度低, 可比同类马达降温18%
4. 节省空间, 装在车板下比同类马达节省10%的体积
5. 容易安装, 可比同类马达少1/2 安装时间
6. 清理顺畅, 拆装容易, 集尘无漏洞
7. 风压可视需求调整大小

1. Two-way suction (rear and front suction). 1/4 HP more than normal standard. (Rear suction is for thread trimmer, front suction is for fabric waste).
2. Quiet. 5dB lower than normal standard.
3. Low temperature. 18% celsius lower than normal standard.
4. Space efficiency. 10% space saved than normal standard.
5. Easy assembly. 50% time saved for assembly.
6. Easy to clean, easy to assemble/disassemble, completed dust collection.
7. Air pressure can be adjusted as required.

可自行组装 self-installation : YES

适用机型 applicable model : MODEL w/CT, MODEL w/DT, MODEL w/VT



CSB

塑胶筒式吸风马达 Plastic Tank Suction Device

1. 单吸马力量，装在车头上比同类马达大1/4的马力量(适用后吸切刀)
 2. 噪音低，可比同类马达降低 5dB
 3. 温度低，可比同类马达降温10%
 4. 节省空间，装在车板下比同类马达节省25%的体积
 5. 容易安装，可比同类马达少1/4 安装时间
 6. 清理顺畅，拆装容易，集尘无漏洞
 7. 风压可视需求调整大小
1. One-way suction, 1/4 HP more than normal standard. (for rear suction thread trimmer)
 2. Quiet, 5dB lower than normal standard.
 3. Low temperature. 10% lower than normal standard.
 4. Space efficiency. 25% space saved than normal standard.
 5. Easy assembly. 25% time saved for assembly.
 6. Easy to clean, easy to assemble/disassemble, completed dust collection.
 7. Air pressure can be adjusted as required.

可自行组装 self-installation : YES

适用机型 applicable model : MODEL w/CT, MODEL w/DT, MODEL w/VT



CT

水平式自动吸风切线装置 Horizontal Pneumatic Type Chain Cutter (Flat Suction)

利用吸风式马达或空压机将线吸入切刀槽中予以切断(较适用于4~6线之机型)
Take thread into trimmer tube by suction motor or air compressor. (Applicable for 4~6 thread machine)

可自行组装 self-installation : YES

适用机型 applicable model : 747K, 757K, 767K,
747Qe, 757Qe, 767Qe



CTE

水平吸风切线 (附电眼节能装置) Flat Suction Chain-Cutter (With Sensor-Controlled Energy-Saving Device)



700Q电控系统支持电眼节能装置，采用电眼侦测布边，利用控制箱调整旋钮，控制吸风功能在切线时运作，减少空压设备的能源消耗，并避免缝线浪费。

700Q's computerized system drives sensor-controlled energy saving device. Electric eye (sensor) checks the fabric edge. Turn the button of control box to set the time of air suction of chain-cutter. It saves the energy consuming of air compressor system and also saves thread consuming.

可自行组装 self-installation : NO

适用机型 applicable model : 747QD, 757QD, 767QD



DK 1 2 3 4

直驱伺服马达 Direct-drive Servo Motor

包缝机模块化搭配直驱伺服马达, 多样化的选择, 更有弹性

1:适用机型 2: 厂别 3: 系列流水号 4:功能等级

Overlock machine equipped with the modularized direct-drive servo motors to be more flexible for diversification.

1: Applicable machine 2: Factory code 3: Series number 4: Function level

可自行组装 self-installation : YES

适用机型 : 全系列包缝机

Applicable model: All Overlock Series



EC

电动式切布条/松紧带条装置 Electric Type Tape / Elastic Cutter

利用手动按钮方式切断松紧带, 不织布条或滚边布条

1. 分标准切刀EC-K (16 mm),长切刀EC-K-A (22 mm)

2. 标准为手动切带,另可选购膝控切带(FEC34-A)

Cuts tape/ elastic by pressing the button.

1. EC-K: Standard knife (16 mm") EC-K-A: Long knife (22 mm")

2. Hand-control button : standard Knee-control paddle (FEC34-A) : Optional

可自行组装 self-installation : YES

适用机型 applicable model :MODEL w/GA/P, MODEL w/LFC-3, MDEL w/PS, MODEL w/TA, MODEL w/TG, MODEL w/TR



ECA

气动式切刀 (自动模式切换功能/附手动)

Pneumatic Type Tape / Thread Cutter (With Auto / Manual Switch Function)

ECB

电动式切刀 (自动模式切换功能/附手动)

Solenoid Type Tape / Thread Cutter (With Auto / Manual Switch Function)

电眼在侦测到车缝完毕时精准下刀。ECA为气动式, ECB为电动式, 搭配吸风线槽, 操作更顺畅。

Advanced sensor inspects the completion of sewing work and initiates cutting without time lag. ECA is pneumatic type, and ECB is electric type, compatible with air suction slot, which makes the operation more smoothly.



	双电眼 Dual Sensor	切刀 Cutter	气动配件 Pneumatic Set			备注 Remark
			抬押脚 Foot Lifter	吸风集尘组 Suction Set	吸风线槽 Suction Channel	
ECA	√	气动 Pneumatic	√	√	√	全功能 Full Function
ECB-A	√	电动 Electric	√	√	√	全功能 Full Function
ECB	√	电动 Electric	X			经济型 Economic

ECB适用: 无空压设备之成衣厂, 或短裁片不抬押脚连续车缝作业

ECB Applicable for: Garment factory without air compressor, or Continually short sewing operation without presser foot lifting.

可自行组装 self-installation : NO

适用机型 applicable model : 737QD, 747QD, 757QD, 767QD





FG

侧带盘 Side Tape Holder

置于桌板右侧放布条用

For tape feeding, on the right side of the table.

可自行组装 self-installation : YES

适用机型 applicable model : MODEL w/GA/P, MDDEL w/PS, MODEL w/TA



GA

摺景装置 Gathering

下层布间歇或连续性不规则折景

P滚边器(喇叭)KV57(入布宽度25mm/出布宽度6mm)依需要可另订，若滚边加绳需另订押具(押具底需磨一条沟)，为一般押具代号多加P，如：P204P

Continuous or intermittent random gathering on lower ply.

P: Piping folder KV57 (tape width 25mm / finish width 6mm) is optional. For piping with rope inside, presser foot requires a trench, which is marked with P at the end of parts code. eg P204P.

可自行组装 self-installation : YES

适用机型 applicable model : 747K-514H4, 747Qe-514H4, 757K-516H4, 757Qe-516H4
747KT-514H



GAL

荷葉邊密拷装置 Flounce/Falbala fine edging

彈性布料密拷時，以壓布桿向下壓住布料邊緣，形成向後拉力，而產生荷葉邊造型，可調整壓力產生不同的波浪效果

Elastic fabric fine serging with a pull-back device makes flounce/ falbala style. Adjust the pressure of pull-back plate to have big or small waves.



可自行组装 self-installation : YES

适用机型 applicable model : 737K-504F2, 737Qe-504F2



GB

前综合送摺景装置 Gathering Device for Top Feed Model

前综合送上下层布间歇或连续性不规则折景

P滚边器(喇叭)KV57(入布宽度 25mm / 出布宽度 6mm)依需要可另订，若滚边加绳需另订押具(押具底需磨一条沟)，为一般押具代号多加P，如：P463P

Continuous or intermittent random gathering on lower ply, for top feed model.

P: Piping folder KV57 (tape width 25mm / finish width 6mm) is optional. For piping with rope inside, presser foot requires a trench, which is marked with P at the end of parts code. e.g. P463P.

可自行组装 self-installation : YES

适用机型 applicable model : 747DFT-514H4, 757DFT-516H4



GL

手套车缝 Glove Sewing

工作手套以橡皮筋束口包缝

Working glove opening serging with rubber band attachment.



可自行组装 self-installation : NO

适用机型 applicable model : 737FS-504M2

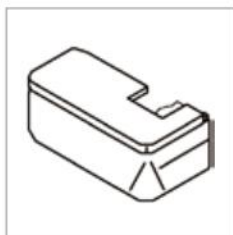

KB561-A 平台式车布导板 Flat Bed Cloth Plate

将筒型车改为平台式, 方便于非筒型衣物包缝

To convert cylinder bed machine into flat bed machine. For normal overlock sewing operation.

可自行组装 self-installation : YES

适用机型 applicable model : 700KS, 700KST



FA 侧向电动送带装置 Side Electric Tape Feeding

1. 利用电子微动开关控制布条, 松紧带或蕾丝之输送长度, 使上带车缝更加平顺
2. 送带在控制箱右边

1. With electronic switch to control the feeding length of tape, elastic, or lace to create smoother sewing.

2. Tape feeding will be on the right hand side of the control box.

可自行组装 self-installation : YES



LFA-A □ 电动式直向送带装置 Electric Type Upper Tape Feeding Device

利用电子马达带动松紧带, 使其放松到零松紧状况, 并可控制所需松紧带之长短, 使车缝时松紧度能一致

□代表电压, 1: 110V, 2: 220V

To keep constant tension for sewing. Elastic tape is fed by motor for zero tension and required length.

□=voltage, 1: 110V, 2: 220V

可自行组装 self-installation : YES

适用机型 applicable model : MODEL w/LFC-3, MODEL w/TG, MODEL w/TR



LF290 -A □ 抖带轮 Untangle Wheel

可选配安装于LFA (送带装置), 以逆转的方式, 抖动松紧带, 做为送带前的处理

□代表电压, 1: 110V, 2: 220V

An optional device to be equipped with LFA (tape feeding device). Untangling the elastic tape by reverse rotation wheel is a pre-feeding process.

□=voltage, 1: 110V, 2: 220V

可自行组装 self-installation : YES

适用机型 applicable model : MODEL w/LFA



LFC-3

机械式松紧带送带装置 Mechanical Type Elastic Feeding

利用齿轮调整控制松紧带之松紧程度; *押具:分3线及4线用如:P216-3,P216-4 (标准品配P216除非下单时注明)

To Control elastic tape tension by adjusting the gear.

Presser foot:

P216-3 for 3 thread

P216-4 for 4 thread

Standard is P216. Special demand by request.

押具代号 Presser Foot	P216	P217	P218	WP219
松紧带尺寸 Elastic Size	2-13mm	2-20mm	2-30mm	2-35mm

可自行组装 self-installation : YES

适用机型 applicable model : 737K-504M2, 747K-514M2



LS

上方带盘 Upper Tape Holder

置于上前方放布条或松紧带

For top feeding tape or elastic.

可自行组装 self-installation : YES

适用机型 applicable model : MODEL w/LFC-3, MODEL w/TG, MODEL w/TR



P(KV57)

折景滚边喇叭 Piping Binder for Gathering

入布宽度 25 mm / 出布宽度 6 mm

Tape width 25 mm / Finish width 6 mm

可自行组装 self-installation : YES

适用机型 applicable model : MODLE w/GA



PS

口袋包边缝合装置 Pocket Sewing

在裤袋边缘多车上一包边布条，以强化缝合处增加美观

喇叭PS201:可用布条宽度为3/8" (9.5mm)

Overlock sewing with tape binding for strengthening the pocket edge.

PS201: Folder, for tape width 3/8" (9.5mm)

可自行组装 self-installation : YES

适用机型 applicable model : 757K-516M2, 757Qe-516M2



PZ

拉链车缝装置 Zip Seaming

将拉链与衣身裁片同时包缝

Overlock sewing for joint between zipper and cloth.

可自行组装 self-installation : YES

适用机型 applicable model : 737K-504M3, 737Qe-504M3



UC

上下层防卷边 Top and Bottom Anti-Curly Edge

针对易卷曲布料所开发的气动装置,在布料进入压脚之前,将布料吹平,可适用上卷,下卷等各种卷曲的情形,大幅增加车缝效率。

The pneumatic device solves the problem of curly edge material. The fabric edge is flattened by air before entering the presser foot. Applicable to up-roll, down-roll, and all kinds of curly edge situations, which highly improves the sewing efficiency.

可自行组装 self-installation : YES

适用机型 applicable model : 700LD/DKLT1-1



TA

双勾针环缝口袋包边缝合装置 Two Chainstitch Pocket Sewing

在裤袋边加包边布条并车两道环缝线,以强化缝合处增加美观,标准喇叭(入布宽度25.4mm/出布宽度6.4mm)

Tape binding by two chainstitch sewing for strengthening the pocket edge. Standard folder(tape width 25.4mm/ finish width 6.4mm)

可自行组装 self-installation : YES

适用机型 applicable model : 757K-401M2-50, 757Qe-401M2-50



TBK
TB-Q1

全沉式机头安装支撑组 Machine Body Supporter for Full Submerged Table

全沉式桌板机头支撑组

700K series machine base for full submerged table.

可自行组装 self-installation : YES

适用桌板 applicable model : Table 700K-T1, Table 700Q-T1



TG

车肩带装置 Tape Guide

在车针织布时多车上一条平织布条,可防止肩部宽变型张开,押具P254J-4A布条最大宽度为13mm

To prevent knit wear shoulder stretching, insert woven tape for strengthening. P254J-4A: Presser foot for maximum tape width is 13 mm.

可自行组装 self-installation : YES

适用机型 applicable model : 747K-514M2, 747Qe-514M2, 747K-514M7, 747Qe-514M7



TR

简易松紧带控制组 Elastic Controller

利用弹簧片简易控制松紧带松紧度,适合不织布或塑胶布浴帽车缝

Applicable for non-woven/ plastic shower cap sewing. Control the tension of elastic by the spring.

可自行组装 self-installation : YES

适用机型 applicable model : 737K-504M2, 737Qe-504M2

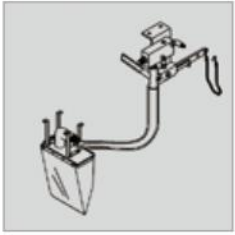

TU

空气阀 Venturi

当踩脚踏板开始车缝时，空压机所供给之压缩空气便会将车缝线吸入切刀槽中予以切断，并使其线屑顺着塑胶管吸入塑胶筒中

When stepped on the pedal for sewing, air from compressor vacuums the thread into the trimmer tube, and then the trimmer cuts the thread. Thread waste is collected by the tube.

可自行组装 self-installation : YES

适用机型 applicable model : MODEL w/CT, MODEL w/DT, MODEL w/VT, Please Refer Motor Page



TW

单针环缝(毛巾车)装置 Towel Edging

适合车毛巾边缘

Applicable for towel edge sewing.

可自行组装 self-installation : YES

适用机型 applicable model : 757K-401, 757Qe-401



VT

垂直吸风式自动切线装置 Vertical Pneumatic Type Chain Cutter (Side Suction)

利用吸风马达或空压机将线吸入切刀槽中予以切断(较适用于3~4线之机型)

Take thread into trimmer tube by suction motor or air compressor. (Applicable for 3-4 thread machine)

可自行组装 self-installation : YES

适用机型 applicable model : 737K, 747K, 737Qe, 747Qe, 737FS, 747FS

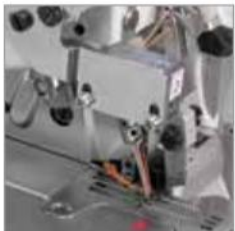

VTE

垂直吸风切线 (附电眼节能装置) Side Suction Chain-Cutter (With Sensor-Controlled Energy)



700Q/700QD电控系统支持电眼节能装置，采用电眼侦测布边，利用控制箱调整旋钮，控制吸风功能在切线时运作，减少空压设备的能源消耗，并避免缝线浪费。

700Q/700QD's computerized system drives sensor-controlled energy saving device. Electric eye (sensor) checks the fabric edge. Turn the button of control box to set the time of air suction of chain-cutter. It saves the energy consuming of air compressor system and also saves thread consuming.

可自行组装 self-installation : NO

适用机型 applicable model : 737QD, 747QD



WR/
LFC-3

管状布条车缝装置(反条装置) Spaghetti Sewing

针织布条之拷边车缝并反条成管形，适用于各种泳衣或睡衣、韵律服等之管形肩带。喇叭布条宽度约22.2mm (7/8")，成型肩带直径5mm

Overlock sewing at knit tape edge and then turn it into tube. For swimwears, night gowns etc. Folder size: tape width is 22.2mm, finished tube size is 5mm in diameter.

可自行组装 self-installation : YES

适用机型 applicable model : 737K

TUA-3X 三合一吸风集尘组 / 3-in-1 Dust Collecting Suction Device

700QD专用吸风集尘组，为电眼机型(ECA, ECB, CTE, VTE)之标准配备，并可适用于700K, 700KT, 700Qe系列，线屑(后吸风)、布屑(前吸风)、棉絮(内吸风)同时清除

700QD clusive suction set is the standard device of sensor-controlled machine (ECA, ECB, CTE, VTE), which cleans away thread ends (rear suction), cloth waste (front suction) and lint (inner suction). Also, TUA-3X is compatible to 700K, 700KT, 700Qe series.

代号 Code	功能组件 Functional Section					选配件 Optional Device	适用机型 Applicable Series	
	三机组 3-in-1 set	抬押脚 (气缸+支架) Presser Foot Lifter (Air cylinder+ bracket)	气阀 Air Switch		滤瓶 Filter			
			机械式 Mechanical Type	电磁阀式 Solenoid Type				
TUA-30		●	●				700K / KS / Qe / L	
TUA-30T		● (大气缸 Big Cylinder)					700KT / KST	
TUA-31	● ①		单联 Single way			VT CT	700K / KS / KST / KT / Qe / L	
TUA-31-A					●			
TUA-32K		K型支架 K type bracket	② 双联 Double ways			VT CT	700K / KS / L	
TUA-32K-A							●	
TUA-32KT	●	● (大气缸 Big Cylinder)						700KT / KST
TUA-32Q		Q型支架 ④ Q type bracket						700Qe
TUA-32Q-A					●			
TUA-33K	●			单联* ③ Single way *		VT CT	700K / KS / KST / KT / L	
TUA-33Q					●		700Q	
TUA-34K		K型支架 K type bracket				VT CT	700K / KS / L	
TUA-34KT	●	● (大气缸 Big Cylinder)		双联* Double ways *	●		700KT / KST	
TUA-34Q		Q型支架 ④ Q type bracket					700Q	

* 備註: 电磁阀需由伺服馬達的電控箱驅動, 接頭規格有8-Pin (質欣MJ系列)與15-Pin(質欣i系列), TSA或簡易直驅系列不支援

* Remark: The solenoid must be driven by servo motor control box. The adapter spec. are 8-Pin (Hohsing MJ series) and 15-Pin (Hohsing i series). TSA Series and Simply type are not applicable

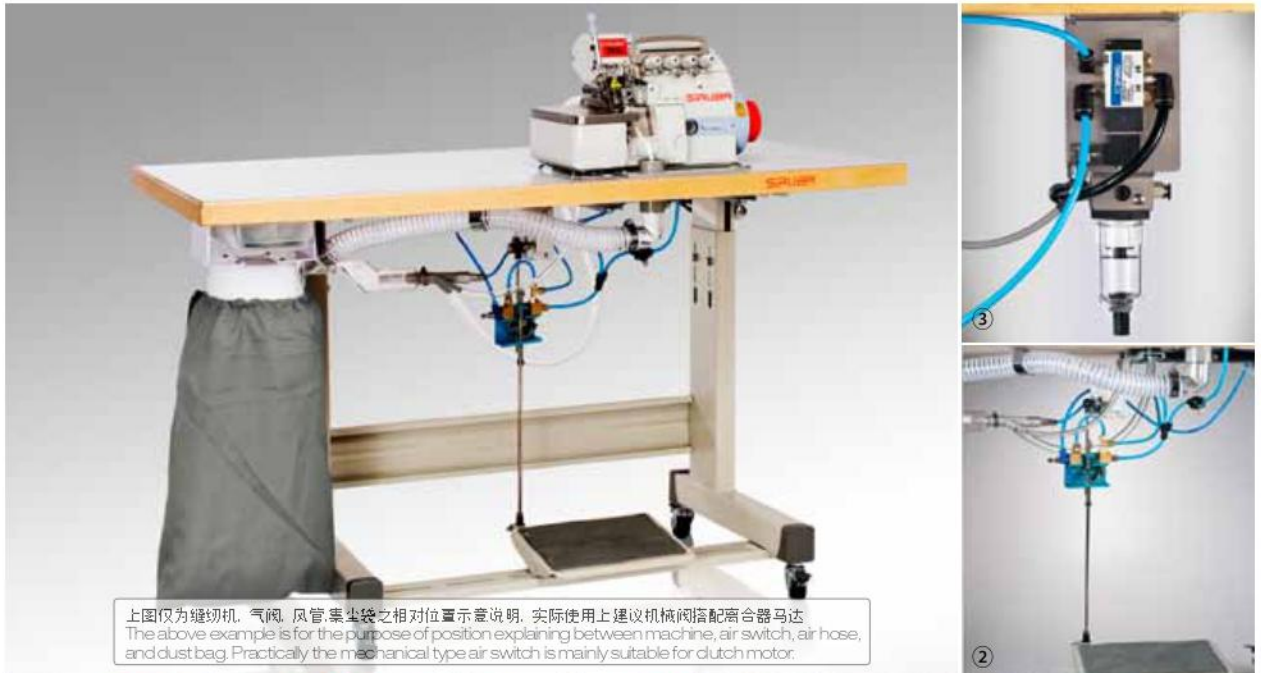

TUB 吸风集尘组 Dust Collecting Suction Device

NO	适用机型 Applicable Type	料号 Part	吸布屑方式 Vacuuming Way			功能组件 Functional Components					马达型式 Motor	
			前吸 Front	后吸 Back	内吸 Inner	抬押脚 Presser Foot Lifter	机械阀 Mechanical Valve	电磁阀 Solenoid	调整过滤器 Adjusting Filter	消音器 Muffler	伺服 Servo	离合器 Clutch
1	拷克 Overlock	TUB-1		√			√					√
2		TUB-3	√	√			√					√
3		TUB-3N	√	√			√			√		√
4		TUB-13	√	√	√	√	√		√			√
5		TUB-14	√	√	√	√	√		√		√	
6	700F 700FS	TUB-2F		√		√	√		√			√
7		TUB-4F	√	√		√	√		√			√
8		TUB-4FN	√	√		√	√		√	√		√
9		TUB-8F		√		√	√		√		√	
10		TUB-10F	√	√		√	√		√		√	
11		TUB-10FN	√	√		√	√		√	√	√	
12	700K 700KT 700KST	TUB-2K		√		√	√		√			√
13		TUB-4K	√	√		√	√		√			√
14		TUB-4KN	√	√		√	√		√	√		√
15		TUB-8K		√		√	√		√		√	
16		TUB-10K	√	√		√	√		√		√	
17		TUB-10KN	√	√		√	√		√	√	√	
18	700KD	TUB-5DS		√		需加购 FLP-1A Additional Order FLP-1A	√		√		√	
19		TUB-5DS1		√		含 FLP-1A Included FLP-1A	√		含抬押脚组 Including the presser foot lifter		√	
20		TUB-6DS	√	√		需加购 FLP-1A Additional Order FLP-1A	√		√		√	
21		TUB-6DSN	√	√			√		√	√	√	
22		TUB-7		√			√				√	
23		TUB-9	√	√			√				√	
24		TUB-9N	√	√			√			√	√	
25	700Q	TUB-11Q		√		需加购 FLQ-A Additional Order FLQ-A		√	√		√	
26		TUB-12Q	√	√				√	√		√	
27		TUB-15Q	√	√	√			√	√		√	

TUD-2 电动型吸风集尘组 Electrical Dust Collecting Suction Device

规格 Specification	
吸布屑方式 Vacuuming Way	前+后 Front + Rear
动力来源 Driven by	无刷吸风马达 Brushless Suction Motor
适用机型 Applicable Model	全机型 All Series
适用配件 Applicable Device	VT/CT



MOTOR

代码 Motor No.		规格 /Specification					适用机型 Applicable Model	备注 Remark
		W	V	Pole	Phase	HZ / R.P.M.		
离合器马达 CLUTCH MOTOR	T3221xx	250W	220	2	1	50HZ/2850R.P.M. 60HZ/3450R.P.M.	700K 757UX 700FS	
	T3222xx		240					
	T3233xx		110					
	T3239xx		230-250					
	T3223xx		380					
	T3224xx		220					
	T3230xx	400W	110	4	1	50HZ/60HZ 5000R.P.M.	700DFT 700FS 700FS/LF-D6 700K 700KS 700KT 700KST 700UX	内置式TSA21-A1 TSA21-A1 (for Built-in Type)
	T3201xx		220					
	T3202xx		240					
	T3203xx		380					
	T3204xx		220					
简易伺服马达 SIMPLIFIED SERVO MOTOR	TSA-400	400W	200-240	4	1	50HZ/60HZ 5000R.P.M.	700DFT 700FS 700FS/LF-D6 700K 700KS 700KT 700KST 700UX	内置式TSA21-A1 TSA21-A1 (for Built-in Type)

CSC

- 2合1两用马达结合离合器马达和吸风马达功能，设计精密，品质优良，故障率低
 - 节能省电，不需有空压设备
 - 降低成本，可少购吸风马达或空压设备
 - 低噪音设计
- 2-in-1 dual motor integrates functions of both clutch motor and suction motor . Precise design ensures good quality and low failure rate.
 - Energy saving. Independent air compressor system.
 - Cost saving, 2-in-1 dual motor saves the cost of suction motor or compressor.
 - Low noise sound level.

代码 Motor No.		规格 /Specification						适用机型 Applicable Model
		W	V	Pole	Phase	HZ	R.P.M.	
离合器马达+吸布屑线装置 CLUTCH MOTOR W/FABRIC & THREAD WASTE VACUUMING DEVICE	CSC-T3601U	400W	110 - 130	2	1	50	2850	MODEL w/CT MODEL w/DT MODEL w/VT
	CSC-T3602U		110					
	CSC-T3603U		220 - 240					
	CSC-T3604U		220					
	CSC-T3605U		110 - 220		3	60	3450	
	CSC-T3606U		200 - 220					
	CSC-T3607U		380 - 440					
	CSC-T3608U		220 - 380					
离合器马达+吸线屑装置 CLUTCH MOTOR W/THREAD WASTE VACUUMING DEVICE	CSC-T3621U	400W	100 - 130	2	1	50	2850	MODEL w/CT MODEL w/DT MODEL w/VT
	CSC-T3622U		110					
	CSC-T3623U		220 - 240					
	CSC-T3624U		220					
	CSC-T3625U		110 - 220		3	60	3450	
	CSC-T3626U		200 - 220					
	CSC-T3627U		380 - 440					
	CSC-T3628U		220 - 380					



CSC-T360xx



CSC-T362xx

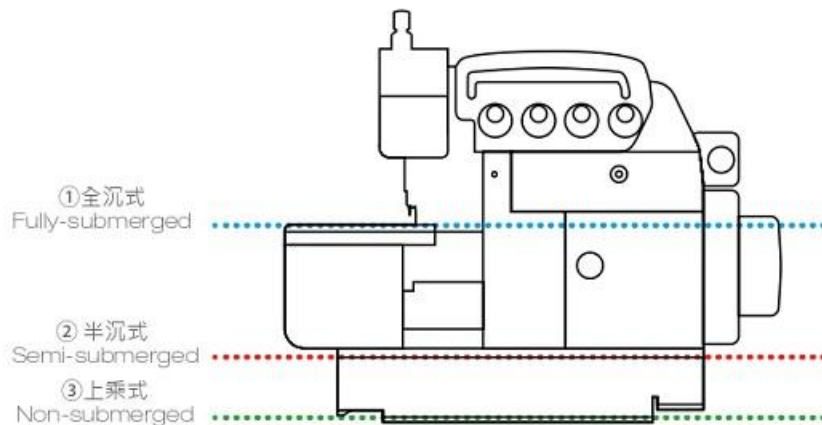

TABLE

桌板代号 Item No.	尺寸 / Size (mm)			说明 Description	适用机型 Applicable Model	备注 Remark
	长 Length	宽 Width	厚 Thickness			
700K-T	1200	540	40	②半沉式 Semi-submerged	700L, 700K, 700KT	
700K-T2	1200	540	40	①全沉式 Fully-submerged	700L, 700K, 700KT	须搭配TBK-1组 TBK-1 set required
700K-T3	1200	540	40	①全沉式 Fully-submerged	700L, 700K/EC,CT,VT	须搭配TBK-1组 TBK-1 set required
700K-T4	1200	540	40	②半沉式 Semi-submerged	700L/BKF, 700K/BKF	
747-T	1200	540	40	②半沉式 Semi-submerged	700DFT/DRT 757UX	
700Q-T	1200	540	40	②半沉式 Semi-submerged	700QD, 700Qe	
700Q-T1	1200	540	40	①全沉式 Fully-submerged	700QD, 700Qe	须搭配TB-Q1 TB-Q1 set required
700KS-T	1200	540	40	②半沉式 Semi-submerged	700KS/KST	
700KS-T1	1200	540	40	②半沉式 Semi-submerged	700KS/KST	

Contact